



*Plastic pipe solutions*



# Pegler Yorkshire

*Unrivalled quality, innovation, customer service and long-term value for money*

As part of the global Aalberts Industries NV Group, Pegler Yorkshire is one of Britain's largest and most respected manufacturers of innovative products for the demanding and diverse plumbing and heating industries.

## Pegler Yorkshire – a unique story

It was in the late 19th century when two separate and altruistic companies set out on the long road to satisfying the needs of prospective customers and, of course, to profit in the process. Coincidentally located just 30 miles apart, each was driven by the same vision and ideals of a no-compromise culture. Cutting corners was never an option and only the best could ever be good enough.

These two companies were Pegler and Yorkshire Fittings. In meeting all the challenges of the 20th and 21st centuries both companies have changed a great deal, the business ethos common to both never has. And now these two like minds have come together as Pegler Yorkshire – a single source of proven, flow control solutions for installers, specifiers and engineers in the domestic, public and commercial markets.

## Reputable and established brands

Just as Pegler and Yorkshire have endured over such a long period, many of the brand names they have created over time are similarly very well established, in many cases as market leaders in their respective categories. The very extensive Pegler Yorkshire product range now comprises more than 15,000 lines – without rival for the choice and coverage it offers and for the number and scope of applications it satisfies.

## A mind for innovation

Brands which endure and are not easily displaced must by definition be the product of innovative thinking and technology that continually stand the test of time. Pegler Yorkshire's no-compromise philosophy will always put new product development high on the agenda, based on not only meeting the needs of today's markets, but also anticipating and meeting customers' future needs.

## The true value of knowledge

As well as the benefit of unparalleled experience of the flow control market and its growth over many decades, Pegler Yorkshire has strong associations with major industry bodies such as those responsible for determining product and performance standards.

The result is a comprehensive store of knowledge and reference which is invaluable in the key areas of research, development and dealing efficiently and accurately with customer enquiries – particularly with regard to product application and suitability.

## A charter for the best in customer service

With such a diverse product range and customer base, Pegler Yorkshire's no-compromise standards of quality, reliability and value for money naturally go hand in hand with the principle of delivering the best in customer service.

## Green awareness and responsibilities

Developing products which reduce the carbon footprint by saving water and energy is only one side of the green issues coin. Pegler Yorkshire is also increasingly committed to recycling key production materials (such as brass), eliminating the need for excessive packaging wherever possible, and looking for new ways in which the company's day-to-day operations can be improved to reduce waste and minimise the impact on the environment.

Likewise, social responsibilities such as supporting employee and local community welfare are aspects of the very fabric and philosophy upon which both Pegler and Yorkshire were founded.

## Standards

Pegler Yorkshire is dedicated to designing, developing and manufacturing products of the highest quality. We are members of numerous standards committees and take an active part in their development. Our products, where applicable, comply with the relevant British, European and International standards. Whatever the latest developments, we guarantee that our products will always meet the latest and highest standards.



## Trade bodies

Pegler Yorkshire is pleased to be associated with several influential industry organisations:



Association of Plumbing and Heating Contractors



The Bathroom Manufacturers Association



Construction Products Association

## Brass

The Brass Page for specifiers, designers, engineers and manufacturers



British Plumbing Employers Council



Builders Merchants Federation



The Copper Development Association



The UK Copper Board



Institute of Plumbing



Heating and Ventilating Contractors Association



Thermostatic Mixing Valve Manufacturers Association



Scottish and Northern Ireland Plumbing Employers Federation



Yorkshire recommends contacting OFTEC for fuel oils advice. [www.oftec.co.uk](http://www.oftec.co.uk)

 This data book has been produced in clearly defined sections to help the user to find relevant information quickly and easily. At the foot of each page there is a reminder of the brochure sections with the relevant page numbers.

## Section 1

### Product range overview

Introduction to Henco

Key features and benefits

Henco Multilayer pipe 4

Henco PVDF Multilayer Fittings 4

Henco Brass Fittings 5

Henco Manifolds 5

Henco Tools and Accessories 6

Standards, approvals and guarantees 7

## Section 2

### Product range details

Sizes, dimensional details

and product codes 8-32

## Section 3

### Technical Data

Applications and manufacturing standards 33-37

Design considerations 38-39

Pressure loss 40-44

System design considerations 45-52

## Section 4

### Installation instructions

Installation 53-58





### Multilayer pipe

Henco multilayer pipe uses a Henco-patented design to exploit the advantages of both engineering polymer and metal pipes. As such, it features a continuous butt-welded aluminium layer sandwiched between inner and outer layers of cross-linked high density polyethylene (PE-Xc), cross bonded to ensure the highest quality and reliability.

The Henco system pipe has been tested and is suitable for the Henco system fittings at temperatures from -20°C to 95°C at a maximum working pressure of 10 bar throughout the range.

#### Features

- Suitable for potable water applications, chilled water and heating systems, food and medical sectors and compressed air
- Available in coil 14mm to 32mm or straight lengths in sizes from 16mm to 63mm
- WRAS Approved
- Includes a range of protection sleeves and pre insulated pipes
- Precise electron beam cross-linking for enhanced pressure and thermal performance
- Highly resistant to aggressive substances
- Aluminium pipe provides effective oxygen barrier and maintains pipe shape
- Butt welding ensures consistent layer thicknesses throughout.

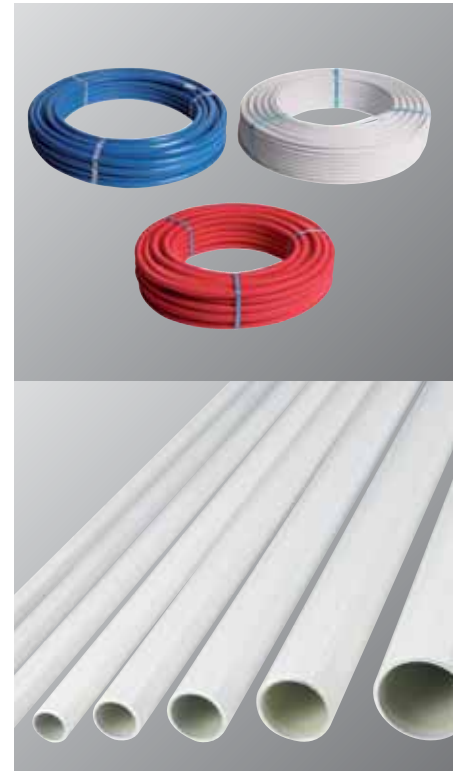

### PVDF press-fit multilayer pipe fittings

Offering excellent mechanical strength, reliability and resistance to thermal ageing, Henco press-fit fittings are manufactured from injection moulded PVDF (Polyvinylidene fluoride). Available in a wide range of configurations, PVDF press-fit fittings are highly cost-effective and offer many advantages over other materials.

The Henco system fittings have been tested and are suitable for Henco pipe at temperatures from -20°C to 95°C at a maximum working pressure of 10bar throughout the range.

#### Features

- Manufactured from Polyvinylidene Fluoride (PVDF)
- Available in sizes from 14mm to 63mm
- Leak Before Press in sizes 14mm to 26mm
- EPDM 'O' rings
- Viewing window to check pipe is fully inserted
- Excellent mechanical strength and hardness
- Stainless steel shoulder to locate jaws of the press tool
- Suitable for potable water applications, chilled water and heating systems, food and medical sectors and compressed air.





## Brass press-fit fittings with Visu-Control® System

Henco multilayer pipe fittings have a unique connection system which provides immediate identification of any fitting which has not been crimped.

### Features

- Viewing window allows pipe to be seen to ensure correct installation
- Fittings are easily connected
- 'O' rings are protected to avoid damage when inserting tube
- Tinned surface prevents corrosion
- WRAS Approved up to 63mm.

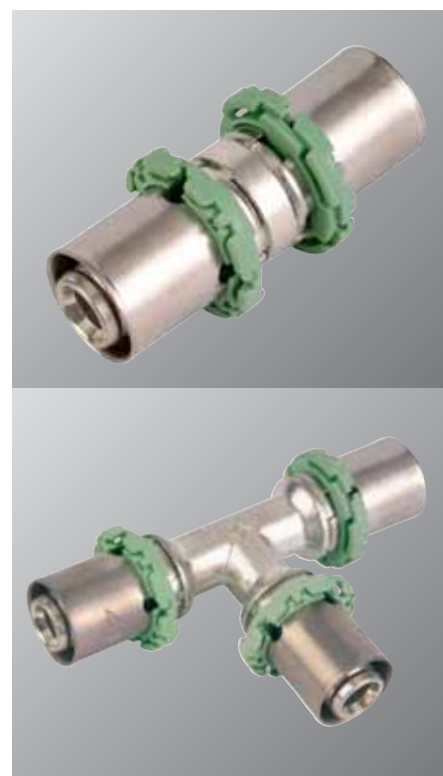

## Manifolds

Henco offers a range of two port manifolds for both heating and sanitary applications.

### Features

- Manufactured in brass and nickel plated brass
- Ports with eurocone connections in a choice of sizes
- Nickel plated manifolds incorporate ball valves.





### Tools and accessories

The Henco range incorporates a host of tools and accessories for extreme ease of installation. These range from pressing jaws and cutting tools through to bending tools. Accessories include pipe clips and protection caps.

#### Features

- Pipe benders, straighteners and decoilers
- Guillotine, wheel and pipe cutters
- Replacement blades for all cutters
- Wide selection of compression jaws, with case
- End caps and re-usable air vent plugs.



The Pegler commercial valve range has been designed with options for connecting to a variety of tubes including multilayer, complimenting the Henco system. For more information visit [www.pegler-yorkshire.co.uk](http://www.pegler-yorkshire.co.uk)



It's Pegler Yorkshire's policy to provide a range of products and services which meet, or exceed, the requirements of our customers in respect of quality, cost and delivery.

## Standards and approvals



GERMANY



ITALY



AUSTRIA



AUSTRIA



FRANCE



THE NETHERLANDS



POLAND



DANMARK  
DENMARK



Australian  
Standard



RUSSIA



SLOVAKIA



ATG SYSTEM CERTIFICATE BELGIUM



SPAIN



FINLAND



HUNGARY



SWEDEN



SWEDEN



ENGLAND



SWITZERLAND



ESTONIA



NORWAY



ICELAND



CZECH REPUBLIC



ROMANIA



SOUTH AFRICA



PORTUGAL

## Guarantees

### 30 YEAR HENCO PRODUCT GUARANTEE



Our policy of continuously and rigorously testing Henco pipe and fittings means we are confident they will

give you years of trouble free service. To demonstrate the total confidence we have in our products and our commitment to customer service, all Henco pipe and fittings are guaranteed against manufacturing defects for 30 years, when installed in accordance with our instructions.

## Multilayer pipes

### Standard (PE-Xc/AL/PE-Xc)

When ordering pipe, please note minimum order is per 'length'. Please specify total meters required and that the total volume is divisible by the number of lengths of pipe.



#### MLCP S3 White multi pipe - straight lengths (3 metre)

Size	Wall thickness (mm)	Aluminium thickness (mm)	Colour	Individual length	Number of lengths	Total bundle quantity	Order code
16mm	2	0.4	White	3m	25	75	85006
20mm	2	0.4	White	3m	16	48	85015
26mm	3	0.5	White	3m	10	30	85018
32mm	3	0.7	White	3m	7	21	85022
40mm	3.5	0.7	White	3m	9	27	85026
50mm	4	0.7	White	3m	7	21	85000
63mm	4.5	0.7	White	3m	4	12	85037



#### MLCP S5 White multi pipe - straight lengths (5 metre)

Size	Wall thickness (mm)	Aluminium thickness (mm)	Colour	Individual length	Number of lengths	Total bundle quantity	Order code
16mm	2	0.4	White	5m	25	125	85008
20mm	2	0.4	White	5m	18	90	85016
26mm	3	0.5	White	5m	10	50	85020
32mm	3	0.7	White	5m	7	35	85024
40mm	3.5	0.7	White	5m	9	45	85028
50mm	4	0.7	White	5m	7	35	85002
63mm	4.5	0.7	White	5m	4	20	85039

When ordering pipe, please note minimum order is per 'length'. Please specify total meters required and that the total volume is divisible by the total meters per coil.



#### MLCPC White multi pipe - coils

Size	Wall thickness (mm)	Aluminium thickness (mm)	Colour	Quantity	Total length (metres)	Order code
14mm	2	0.4	White	1	50	85040
14mm	2	0.4	White	1	100	85042
16mm	2	0.4	White	1	50	85046
16mm	2	0.4	White	1	100	85047
16mm	2	0.4	White	1	200	85045
20mm	2	0.4	White	1	100	85048
26mm	3	0.7	White	1	50	85050
32mm	3	0.7	White	1	50	85051



### MLCPRC Standard pipe with colour coded conduit in red

Size	Wall thickness (mm)	Aluminium thickness (mm)	Colour	Quantity	Total length (metres)	Order code
14mm	2	0.4	Red	1	25	85052
14mm	2	0.4	Red	1	50	85053
14mm	2	0.4	Red	1	100	85054
16mm	2	0.4	Red	1	25	85055
16mm	2	0.4	Red	1	50	85058
16mm	2	0.4	Red	1	100	85059
20mm	2	0.4	Red	1	25	85060
20mm	2	0.4	Red	1	50	85061
26mm	3	0.5	Red	1	50	85065
32mm	3	0.7	Red	1	25	85066

When ordering pipe, please note minimum order is per 'length'. Please specify total meters required and that the total volume is divisible by the total meters per coil.



### MLCPBC Standard pipe with colour coded conduit in blue

Size	Wall thickness (mm)	Aluminium thickness (mm)	Colour	Quantity	Total length (metres)	Order code
14mm	2	0.4	Blue	1	25	85067
14mm	2	0.4	Blue	1	50	85068
14mm	2	0.4	Blue	1	100	85069
16mm	2	0.4	Blue	1	25	85070
16mm	2	0.4	Blue	1	50	85073
16mm	2	0.4	Blue	1	100	85074
20mm	2	0.4	Blue	1	25	85075
20mm	2	0.4	Blue	1	50	85076
26mm	3	0.5	Blue	1	50	85078
32mm	3	0.7	Blue	1	25	85077



### MLCPP612 Pre-insulated coil red (6mm)

Size	Wall thickness (mm)	Aluminium thickness (mm)	Colour	Quantity	Total length (metres)	Order code
14mm	2	0.4	Red	1	100	85095
16mm	2	0.4	Red	1	100	85096
20mm	2	0.4	Red	1	50	85098
26mm	3	0.5	Red	1	25	85099
26mm	3	0.5	Red	1	50	85100
32mm	3	0.7	Red	1	25	85101



### MLCPP6B Pre-insulated coil blue (6mm)

Size	Wall thickness (mm)	Aluminium thickness (mm)	Colour	Quantity	Total length (metres)	Order code
14mm	2	0.4	Blue	1	100	85102
16mm	2	0.4	Blue	1	100	85103
20mm	2	0.4	Blue	1	50	85105
26mm	3	0.5	Blue	1	25	85106
26mm	3	0.5	Blue	1	50	85107
32mm	3	0.7	Blue	1	25	85108



## Multilayer pipes

When ordering pipe, please note minimum order is per 'length'. Please specify total meters required and that the total volume is divisible by the total meters per coil.



### MLCPP10R Pre-insulated coil red (10mm)

Size	Wall thickness (mm)	Aluminium thickness (mm)	Colour	Quantity	Total length (metres)	Order code
14mm	2	0.4	Red	1	50	85110
16mm	2	0.4	Red	1	50	85111
20mm	2	0.4	Red	1	50	85113
26mm	3	0.5	Red	1	25	85114
32mm	3	0.7	Red	1	25	85116



### MLCPP10B Pre-insulated coil blue (10mm)

Size	Wall thickness (mm)	Aluminium thickness (mm)	Colour	Quantity	Total length (metres)	Order code
14mm	2	0.4	Blue	1	50	85118
16mm	2	0.4	Blue	1	50	85119
20mm	2	0.4	Blue	1	50	85121
26mm	3	0.5	Blue	1	25	85122
32mm	3	0.7	Blue	1	25	85124



### MLCPP13B Pre-insulated coil blue (13mm)

Size	Wall thickness (mm)	Aluminium thickness (mm)	Colour	Quantity	Total length (metres)	Order code
16mm	2	0.4	Blue	1	50	85126
20mm	2	0.4	Blue	1	50	85128
26mm	3	0.5	Blue	1	50	85129
32mm	3	0.7	Blue	1	25	85130

## RIXc (PE-Xc/AL/PE-Xc)



### RIXc White multi pipe - coils. *Not WRAS approved*

Size	Wall thickness (mm)	Aluminium thickness (mm)	Colour	Quantity	Total length (metres)	Order code
16mm	2	0.2	White	1	50	85080
16mm	2	0.2	White	1	100	85081
20mm	2	0.2	White	1	100	85082

## PVDF press-fit fittings

### TYPE: 1PK Elbow

Size	L	D	Order code
14 x 14mm	46	20	85304
16 x 16mm	47	22	85305
20 x 20mm	49	26	85307
26 x 26mm	54	32	85308
32 x 32mm	72	39	85309
40 x 40mm	78	47	85310
50 x 50mm	100	57	85311
63 x 63mm	116	70	85312

Connection: Press-fit x press-fit.

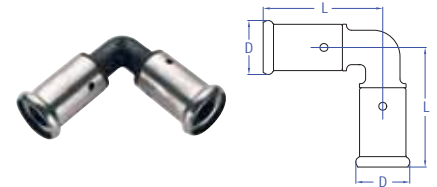

### TYPE: 2PK Backplate elbow female

Size	L1	L2	D1	D2	Rp	T	Order code
14mm x 1/2"*	56	52	20	33	1/2"	13.5	85337
16mm x 3/8"	56	52	22	33	3/8"	13.5	85338
16mm x 1/2"*	56	52	22	33	1/2"	13.5	85339
20mm x 1/2"*	56	52	26	33	1/2"	13.5	85341
20mm x 3/4"	61	58	26	40	3/4"	15.5	85342
26mm x 3/4"	66	58	32	40	3/4"	15.5	85343

Connection: Press-fit x BSP parallel female thread.

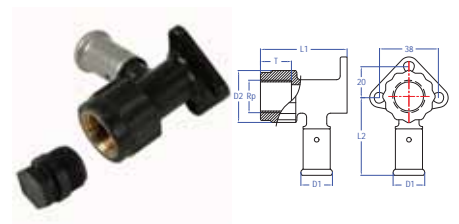

### TYPE: 2PK-K Backplate elbow female, short model

Size	L1	L2	D1	D2	Rp	T	Order code
16mm x 1/2"*	40	52	22	33	1/2"	13.5	85344

Connection: Press-fit x BSP parallel female thread.

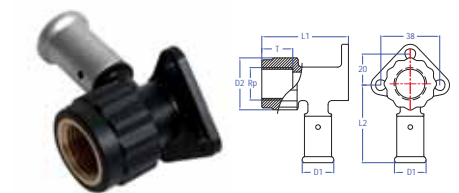

### TYPE: 3PK Double backplate elbow female, short model

Size	L1	L2	D1	D2	Rp	T	Order code
16 x 1/2" x 16mm*	60	42	22	33	1/2"	14	85345
20 x 1/2" x 20mm*	60	43.5	26	33	1/2"	14	85346

Connection: Press-fit x BSP parallel female thread x press-fit.

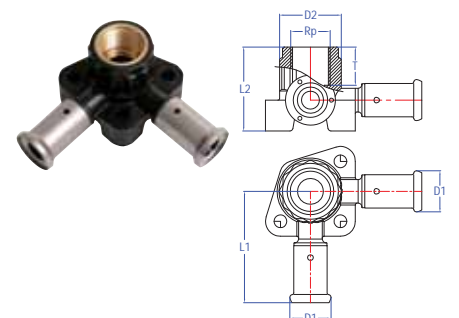

\*With black plug BPO4 1/2" male.

### Tee specification

See page 38

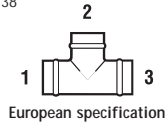
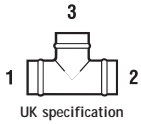

## PVDF press-fit fittings

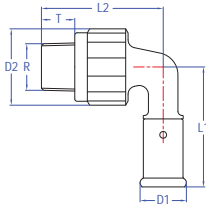

### TYPE: 5PK Bent male elbow iron adapter 90°

Size	L1	L2	D1	D2	Rp	T	Order code
14mm x 1/2"	54	54	20	33	1/2"	13.5	85313
16mm x 1/2"	54	54	22	33	1/2"	13.5	85314
20mm x 1/2"	56	56	26	33	1/2"	13.5	85316
20mm x 3/4"	58	58	26	40	3/4"	14.5	85317
26mm x 3/4"	60	62	32	40	3/4"	14.5	85318
32mm x 1"	75	68.5	39	45.5	1"	16.5	85319
40mm x 1 1/4"	84	77	47	56.5	1 1/4"	19	85320
50mm x 1 1/4"	101	86	57	56.5	1 1/4"	19	85321
50mm x 1 1/2"	101	93	57	70	1 1/2"	20	85322
63mm x 2"	126	118	70	90	2"	23	85323

Connection: Press-fit x BSP parallel male thread.

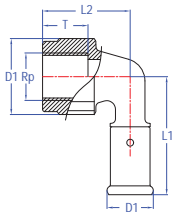

### TYPE: 6PK Bent female elbow iron adapter 90°

Size	L1	L2	D1	D2	Rp	T	Order code
14mm x 1/2"*	53	39	20	33	1/2"	13.5	85325
16mm x 3/8"	53	39	22	33	3/8"	13.5	85327
16mm x 1/2"*	53	39	22	33	1/2"	13.5	85329
20mm x 1/2"*	53	39	26	33	1/2"	13.5	85330
20mm x 3/4"	60	47.5	26	40	3/4"	15.5	85331
26mm x 3/4"	60	47.5	32	40	3/4"	15.5	85332
32mm x 1"	75	58.5	39	45.5	1"	18	85333
40mm x 1 1/4"	81	72	47	56.5	1 1/4"	21	85334
50mm x 1 1/4"	101	77	57	56.5	1 1/4"	21	85335
50mm x 1 1/2"	101	82	57	70	1 1/2"	25	85336
63mm x 2"	126	104	70	90	2"	30	85347

Connection: Press-fit x BSP parallel female thread.

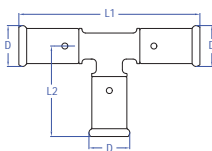

### TYPE: 9PK Equal Tee

Size	L1	L2	D	Order code
14 x 14 x 14mm	93	46	20	85351
16 x 16 x 16mm	94	47	22	85352
20 x 20 x 20mm	98	49	26	85354
26 x 26 x 26mm	107	53	32	85355
32 x 32 x 32mm	140	70	39	85356
40 x 40 x 40mm	151	75	47	85357
50 x 50 x 50mm	191	95	57	85358
63 x 63 x 63mm	232	117	70	85359

Connection: Press-fit x press-fit x press-fit.

\*With black plug BP04 1/2" male.



## Tee specification

See page 38

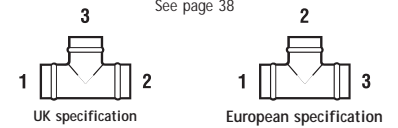

# 2

### TYPE: 10PK Tee, reduced branch

Size UK	European	L1	L2	D1	D2	Order code
16 x 16 x 14mm	16 x 14 x 16mm	95	47.5	22	20	85360
20 x 20 x 16mm	20 x 16 x 20mm	94	49	26	22	85363
26 x 26 x 16mm	26 x 16 x 26mm	98	53	32	22	85365
26 x 26 x 20mm	26 x 20 x 26mm	103	54	32	26	85367
32 x 32 x 16mm	32 x 16 x 32mm	133	58	39	22	85368
32 x 32 x 20mm	32 x 20 x 32mm	133	58	39	26	85370
32 x 32 x 26mm	32 x 26 x 32mm	133	58	39	32	85371
40 x 40 x 16mm	40 x 16 x 40mm	120	59	47	22	85372
40 x 40 x 20mm	40 x 20 x 40mm	123	59	47	26	85373
40 x 40 x 26mm	40 x 26 x 40mm	136	61	47	32	85374
40 x 40 x 32mm	40 x 32 x 40mm	144	75	47	39	85375
50 x 50 x 20mm	50 x 20 x 50mm	160	64	47	26	85376
50 x 50 x 26mm	50 x 26 x 50mm	160	64	57	32	85377
50 x 50 x 32mm	50 x 32 x 50mm	167	77	57	39	85378
50 x 50 x 40mm	50 x 40 x 50mm	184	81	57	47	85379
63 x 63 x 26mm	63 x 26 x 63mm	187	71	70	32	85380
63 x 63 x 32mm	63 x 32 x 63mm	193	84	70	39	85381
63 x 63 x 40mm	63 x 40 x 63mm	212	87	70	47	85382
63 x 63 x 50mm	63 x 50 x 63mm	220	103	70	57	85383

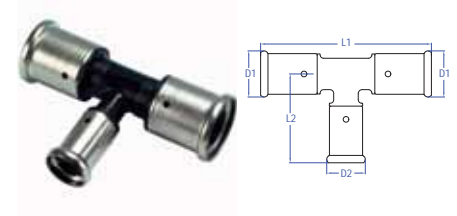

Connection: Press-fit x press-fit x press-fit.

### TYPE: 11PK Tee, one end reduced

Size UK	European	L1	L2	L3	D1	D2	D3	Order code
20 x 16 x 20mm	20 x 20 x 16mm	49.5	51	49.5	26	26	22	85384
26 x 16 x 26mm	26 x 26 x 16mm	53.5	56	53.5	32	32	22	85385
26 x 20 x 26mm	26 x 26 x 20mm	53.5	54.5	53.2	32	32	26	85386
40 x 26 x 40mm	40 x 40 x 26mm	74.5	70.5	75.5	47	47	32	85387
40 x 32 x 40mm	40 x 40 x 32mm	74.5	74.5	75.5	47	47	39	85388

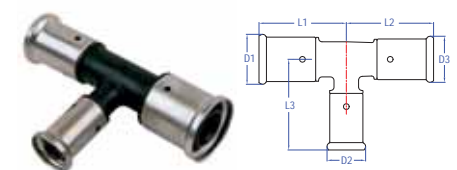

Connection: Press-fit x press-fit x press-fit.

### Tee specification

See page 38

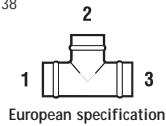
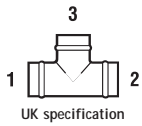

## PVDF press-fit fittings

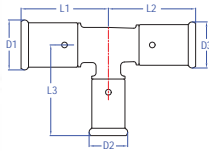

### TYPE: 11PK Tee, one end and branch reduced

Size		L1	L2	L3	D1	D2	D3	Order code
UK	European							
16 x 14 x 14mm	16 x 14 x 14mm	47.5	47.5	47	22	20	20	85389
20 x 16 x 16mm	20 x 16 x 16mm	47.5	49.5	49.5	26	22	22	85391
26 x 20 x 16mm	26 x 16 x 20mm	51.8	51.8	53.5	32	22	26	85393
26 x 16 x 20mm	26 x 20 x 16mm	51.5	51.5	53.2	32	26	22	85394
26 x 20 x 20mm	26 x 20 x 20mm	51.8	51.8	54	32	26	26	85395
32 x 26 x 20mm	32 x 20 x 26mm	66.8	60	58.5	39	26	32	85396
32 x 26 x 26mm	32 x 26 x 26mm	66.3	60	58.5	39	32	32	85397
40 x 32 x 20mm	40 x 20 x 32mm	62	62	59	47	26	39	85398
40 x 32 x 26mm	40 x 26 x 32mm	68	72	61.4	47	32	39	85399
40 x 32 x 32mm	40 x 32 x 32mm	70.5	70.5	72	47	39	39	85400
50 x 40 x 20mm	50 x 20 x 40mm	78	65	64	57	26	47	85401
50 x 40 x 26mm	50 x 26 x 40mm	80	65	64	57	32	47	85402
50 x 40 x 32mm	50 x 32 x 40mm	84	68	77	57	39	47	85403
50 x 40 x 40mm	50 x 40 x 40mm	88	73	77	57	47	47	85404

Connection: Press-fit x press-fit x press-fit.

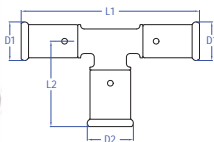

### TYPE: 12PK Tee, both ends reduced

Size		L1	L2	D1	D2	Order code
UK	European					
16 x 16 x 20mm	16 x 20 x 16mm	101	48.5	22	26	85406
20 x 20 x 26mm	20 x 26 x 20mm	108	52	26	32	85407
26 x 26 x 32mm	26 x 32 x 26mm	114	66	32	39	85408
32 x 32 x 40mm	32 x 40 x 32mm	145	69	39	47	85409
40 x 40 x 50mm	40 x 50 x 40mm	154	88	47	57	85410

Connection: Press-fit x press-fit x press-fit.

## Tee specification

See page 38



# 2

### TYPE: 13PK Female branch tee

Size UK	European	L1	L2	D1	D2	D3	Rp	T	Order code
16 x 16mm x 1/2"	16 x 1/2" x 16mm	109	39	22	22	33	1/2"	13.5	85411
20 x 20mm x 1/2"*	20 x 1/2" x 20mm	109	39	26	26	33	1/2"	13.5	85413
20 x 20mm x 3/4"	20 x 3/4" x 20mm	119	47	26	26	40	3/4"	15.5	85414
26 x 20mm x 1/2"*	26 x 1/2" x 20mm	109	43	26	32	33	1/2"	13.5	85415
26 x 26mm x 1/2"*	26 x 1/2" x 26mm	109	43	32	32	33	1/2"	13.5	85416
26 x 26mm x 3/4"	26 x 3/4" x 26mm	119	47	32	32	40	3/4"	15.5	85417
32 x 32mm x 3/4"	32 x 3/4" x 32mm	146	52.5	39	39	40	3/4"	15.5	85418
32 x 32mm x 1"	32 x 1" x 32mm	149	56	39	39	45.5	1"	18	85419
32 x 32mm x 1 1/4"	32 x 1 1/4" x 32mm	161	66	39	39	56.5	1 1/4"	21	85420
40 x 40mm x 1"	40 x 1" x 40mm	153	63	47	47	45.5	1"	18	85421
40 x 40mm x 1 1/4"	40 x 1 1/4" x 40mm	158	69	47	47	56.5	1 1/4"	21	85422
50 x 50mm x 1 1/2"	50 x 1 1/2" x 50mm	202	84	57	57	70	1 1/2"	25	85423
63 x 63mm x 2"	63 x 2" x 63mm	242	104	70	70	90	2"	30	85424

Connection: Press-fit x BSP parallel female thread x press-fit.

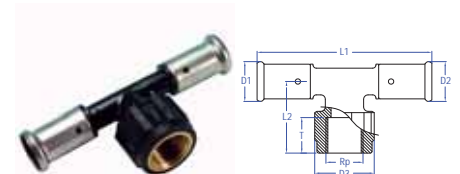

### TYPE: 14PK Male branch tee

Size UK	European	L1	L2	D1	D2	R	T	Order code
16 x 16mm x 1/2"	16 x 1/2" x 16mm	109	54	22	33	1/2"	13.5	85426
20 x 20mm x 1/2"	20 x 1/2" x 20mm	109	54	26	33	1/2"	13.5	85428
20 x 20mm x 3/4"	20 x 3/4" x 20mm	114	58	26	40	3/4"	14.5	85438
26 x 26mm x 1/2"	26 x 1/2" x 26mm	119	60	32	33	1/2"	13.5	85430
26 x 26mm x 3/4"	26 x 3/4" x 26mm	119	63	32	40	3/4"	14.5	85431
26 x 26mm x 1"	26 x 1" x 26mm	124	65	39	45.5	1"	16.5	85432
32 x 32mm x 3/4"	32 x 3/4" x 32mm	146	66	39	40	3/4"	14.5	85433
40 x 40mm x 1"	40 x 1" x 40mm	150	74	47	45.5	1"	16.5	85434
40 x 40mm x 1 1/4"	40 x 1 1/4" x 40mm	161	80	47	56.5	1 1/4"	19	85435
50 x 50mm x 1 1/2"	50 x 1 1/2" x 50mm	202	88	57	70	1 1/2"	20	85436
63 x 63mm x 2"	63 x 2" x 63mm	236	109	70	90	2"	23	85437

Connection: Press-fit x BSP parallel male thread x press-fit.

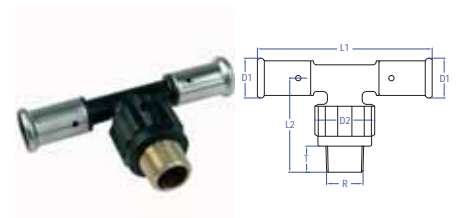

\*For use with black plug BP04 1/2" male.

## PVDF press-fit fittings

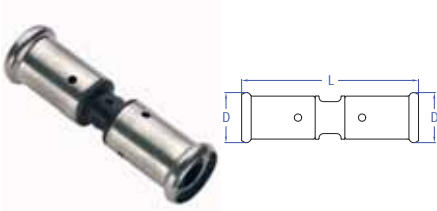

### TYPE: 15PK Straight coupling

Size	L	D	Order code
14 x 14mm	74	20	85250
16 x 16mm	74	22	85251
20 x 20mm	76	26	85253
26 x 26mm	81	32	85254
32 x 32mm	103	39	85255
40 x 40mm	106	47	85256
50 x 50mm	141	57	85257
63 x 63mm	171	70	85258

Connection: Press-fit x press-fit.

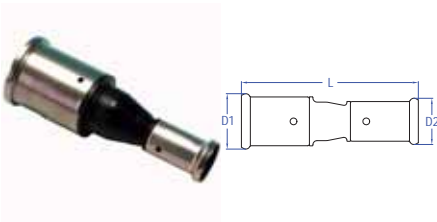

### TYPE: 16PK Reducing coupling

Size	L	D1	D2	Order code
16 x 14mm	80.6	22	20	85259
20 x 16mm	80.8	26	22	85260
26 x 16mm	84	32	22	85261
26 x 20mm	84	32	26	85262
32 x 16mm	107	39	22	85263
32 x 20mm	103	39	26	85264
32 x 26mm	102	39	32	85265
40 x 26mm	113.8	47	32	85266
40 x 32mm	115	47	39	85271
50 x 32mm	136	57	39	85272
50 x 40mm	143	57	47	85273
63 x 40mm	174	70	47	85274
63 x 50mm	173	70	57	85275

Connection: Press-fit x press-fit.



**TYPE: 17PK Straight male coupling iron connector**

Size	L	D1	D2	R	T	Order code
14mm x 1/2"	75	20	33	1/2"	13.5	85290
16mm x 1/2"	75	22	33	1/2"	13.5	85291
20mm x 1/2"	75	26	33	1/2"	13.5	85294
20mm x 3/4"	77	26	40	3/4"	14.5	85295
26mm x 3/4"	77	32	40	3/4"	14.5	85296
26mm x 1"	80	32	45.5	1"	16.5	85297
32mm x 1"	91	39	45.5	1"	16.5	85298
32mm x 1 1/4"	99	39	56.5	1 1/4"	19	85299
40mm x 1"	84	47	45.5	1"	16.5	85300
40mm x 1 1/4"	93	47	56.5	1 1/4"	19	85301
50mm x 1 1/2"	142	57	70	1 1/2"	20	85302
63mm x 2"	142	70	90	2"	23	85303

Connection: Press-fit x BSP parallel male thread.

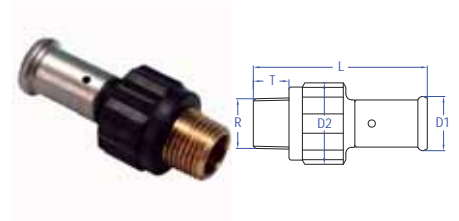
**TYPE: 18PK Straight female coupling iron connector**

Size	L	D1	D2	Rp	T	Order code
14mm x 1/2"	59.5	20	33	1/2"	13.5	85276
16mm x 1/2"	59.5	22	33	1/2"	13.5	85277
20mm x 1/2"	59.5	26	33	1/2"	13.5	85280
20mm x 3/4"	63	26	40	3/4"	15.5	85281
26mm x 3/4"	63	32	40	3/4"	15.5	85282
26mm x 1"	70.5	32	45.5	1"	18	85283
32mm x 1"	82	39	45.5	1"	18	85284
32mm x 1 1/4"	90	39	56.5	1 1/4"	21	85285
40mm x 1"	74.5	47	45.5	1"	18	85286
40mm x 1 1/4"	85	47	56.5	1 1/4"	21	85287
50mm x 1 1/2"	107.5	57	70	1 1/2"	25	85288
63mm x 2"	131	70	90	2"	30	85289

Connection: Press-fit x BSP parallel female thread.

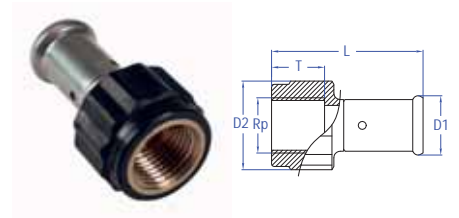
**TYPE: 27PK 45° obtuse elbow**

Size	L	D	Order code
40 x 40mm	63	47	85348
50 x 50mm	84	57	85349
63 x 63mm	102	70	85350

Connection: Press-fit x press-fit.

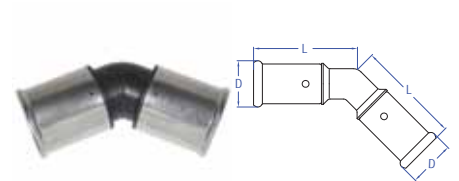

## PVDF press-fit fittings



### TYPE: DRILLY Temporary air vent plug, reusable

Size	Order code
14mm	85450
16mm	85451
18mm	85452
20mm	85453
26mm	85454
32mm	85455

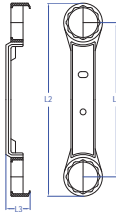

### TYPE: 28PK-04 Clip for 28PK - 2PK1604/6PK1604/13PK160416

Size	L1	L2	L3	Order code
1/2"	153	192	26	85457



### TYPE: 28PK-2PK 10604BP Double backplate 153mm centres for 2PK-1604

Size	Order code
2 x (16mm x 1/2")*	85460

Connection: Press-fit x BSP parallel female thread.

\*For use with black plug BP04 1/2" male.

# Brass press-fit fittings

## SM1 Straight coupling

Size	A	B	Order code
14mm	58	24	84000M
16mm	58	26	84001M
20mm	58	30	84003M
26mm	60	36	84004M
32mm	62	42	84005M
40mm	64	50	84110M
50mm	101	60	84111M
63mm	101	73	84112M

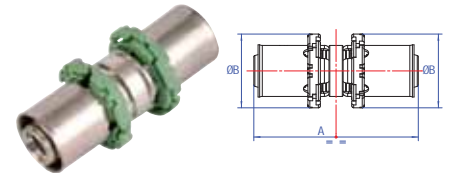

## SM1R Reducing coupling

Size	A	B	C	Order code
16 x 14mm	60	26	24	84017M
20 x 14mm	60	30	24	84018M
20 x 16mm	60	30	26	84019M
26 x 16mm	61	36	26	84021M
26 x 20mm	61	36	30	84023M
32 x 16mm	63	42	26	84024M
32 x 20mm	63	42	30	84026M
32 x 26mm	64	42	36	84027M
40 x 26mm	66	50	36	84034M
40 x 32mm	66	50	42	84035M
50 x 32mm	85.5	60	42	84036M
50 x 40mm	85.5	60	50	84037M
63 x 40mm	83.5	73	50	84038M
63 x 50mm	101	73	60	84039M

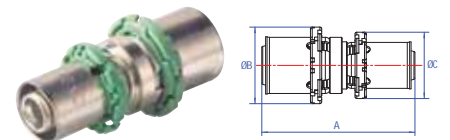

## SM1C Adaptor CU compression

Size	A	B	C	Order code
16 x 15mm	54	26	24	84042M
20 x 22mm	54.1	30	32	84043M
26 x 22mm	55.1	36	32	84044M

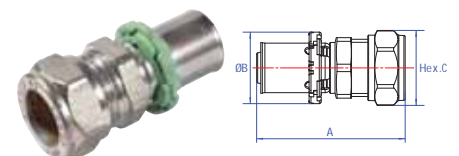

## Brass press-fit fittings

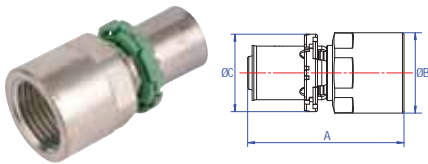

### SM2 Straight female coupling

Size	A	B	C	Order code
14mm x 1/2"	52.5	27	24	84080M
16mm x 1/2"	52.5	27	26	84081M
20mm x 1/2"	52.5	27	30	84084M
20mm x 3/4"	54.5	33	30	84085M
26mm x 3/4"	55.5	33	36	84086M
26mm x 1"	55.5	40	36	84087M
32mm x 1"	55.5	40	42	84088M
40mm x 3/4"	49	50	50	84093M
40mm x 1 1/4"	61.5	48	50	84094M
50mm x 1 1/2"	76.5	63	60	84095M
63mm x 2"	80.5	71	73	84096M

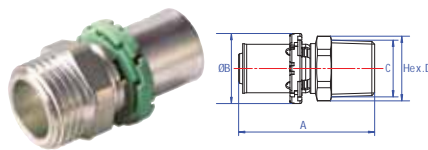

### SM3 Straight male coupling (taper)

Size	A	B	C	D	Order code
14mm x 1/2"	50.5	24	UNI ISO7/1 - R1/2"	22	84050M
16mm x 1/2"	50.5	26	UNI ISO7/1 - R1/2"	22	84051M
20mm x 1/2"	50.5	30	UNI ISO7/1 - R1/2"	22	84054M
20mm x 3/4"	51.5	30	UNI ISO7/1 - R3/4"	27	84055M
26mm x 3/4"	52.5	36	UNI ISO7/1 - R3/4"	30	84056M
26mm x 1"	55.5	36	UNI ISO7/1 - R1"	34	84057M
32mm x 1"	55.5	42	UNI ISO7/1 - R1"	34	84058M
40mm x 1 1/4"	56.5	50	UNI ISO7/1 - R1 1/4"	45	84062M
50mm x 1 1/2"	84	60	UNI ISO7/1 - R1 1/2"	52	84063M
63mm x 2"	85.5	73	UNI ISO7/1 - R2"	66	84064M

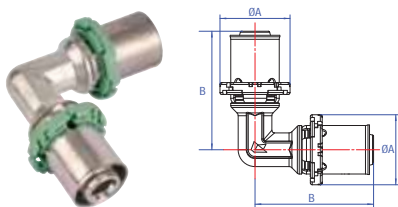

### SM12 Elbow

Size	A	B	Order code
14mm	24	44	84140M
16mm	26	44	84141M
20mm	30	50.5	84143M
26mm	36	54	84144M
32mm	42	54	84145M
40mm	50	54	84137M
50mm	60	77	84138M
63mm	73	85.5	84139M



## SM12C Elbow CU compression

Size	A	B	C	D	Order code
16 x 15mm	50	39	26	24	84190M
20 x 22mm	53	45.6	30	32	84191M
26 x 22mm	54	45.6	36	32	84192M

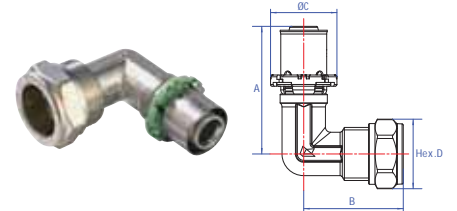

## SM12S Street elbow CU

Size	A	B	C	D	Order code
16 x 2 x 15mm	15	150	44	26	84806M
20 x 2 x 22mm	22	60	53	30	84807M
26 x 3 x 22mm	22	60	54	36	84808M

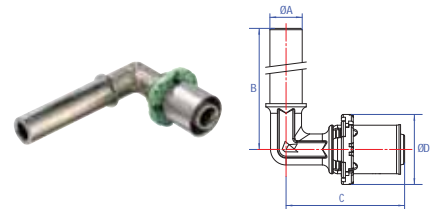

## SM12SLB Long street elbow (extended end 300mm)

Size	A	B	C	D	Order code
16 x 15mm	15	300	80.5	26	84212M
20 x 15mm	15	300	80.5	30	84214M

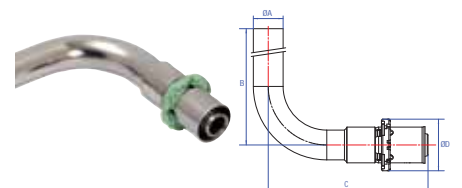

## SM13 Male elbow (taper)

Size	A	B	C	D	Order code
16mm x 1/2"	26	50	33.5	UNI ISO7/1-R1/2"	84161M
20mm x 1/2"	30	50	33.5	UNI ISO7/1-R1/2"	84163M
20mm x 3/4"	30	50	34.5	UNI ISO7/1-R3/4"	84164M
26mm x 3/4"	36	54	39	UNI ISO7/1-R3/4"	84165M
32mm x 1"	42	54	45.5	UNI ISO7/1-R1"	84166M
40mm x 1 1/4"	50	54	53	UNI ISO7/1-R1 1/4"	84168M

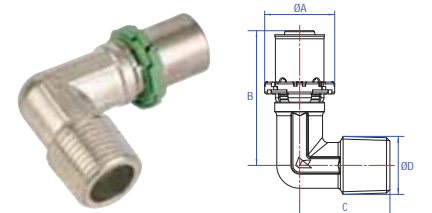

## SM14 Female elbow

Size	A	B	C	D	Order code
16mm x 1/2"	26	50	34	26.5	84176M
20mm x 1/2"	30	50	34	26.5	84178M
20mm x 3/4"	30	53	42.5	33	84179M
26mm x 3/4"	36	54	42.5	33	84180M
32mm x 1"	42	54	49	39	84181M
40mm x 1 1/4"	50	54	55.5	48	84184M
50mm x 1 1/2"	60	77	60	55	84185M

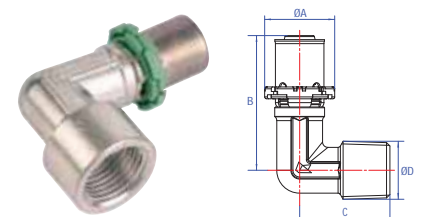

### Tee specification

See page 38

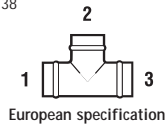
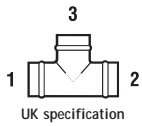

## Brass press-fit fittings

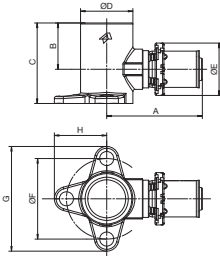

### SM15 Backplate elbow

Size	A	B	C	D	E	F	G	H	Order code
14mm x 1/2"	47.5	23	40	26	24	40	52	26	84375M
16mm x 1/2"	47.5	23	40	26	26	40	52	26	84376M
20mm x 1/2"	47.5	23	40	26	30	40	52	26	84378M

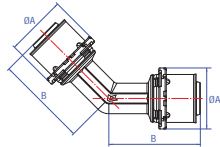

### SM21 Obtuse elbow

Size	A	B	Order code
26mm	36	54	84150M
32mm	42	54.25	84151M
40mm	50	54	84155M
50mm	60	77	84156M
63mm	73	85.5	84157M

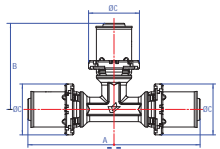

### SM24 Equal tee

Size	A	B	C	Order code
14mm	88	44	24	84225M
16mm	88	44	26	84226M
20mm	101	50.5	30	84228M
26mm	108	54	36	84229M
32mm	108.5	54.25	42	84230M
40mm	108	54	50	84234M
50mm	154	77	60	84235M
63mm	171	85.5	73	84236M

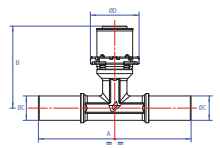

### SM24S Tee, street ends

Size	A	B	C	D	Order code
15 x 15 x 20mm	94	50.5	15	30	84809M
15 x 15 x 26mm	94	54	15	36	84810M
22 x 22 x 26mm	110	54	22	36	84811M

## Tee specification

See page 38

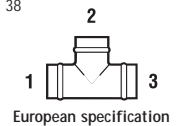
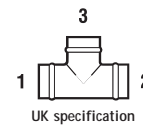

# 2

### SM24SB Long branch street tee

Size	A	B	C	D	Order code
16 x 15mm	86	26	15	300	84271M
20 x 15mm	86	30	15	300	84273M

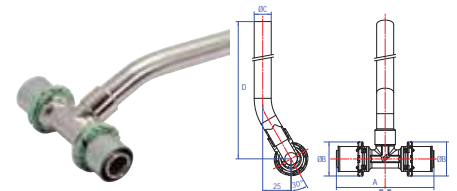

### SM25 Tee, reduced branch

Size	A	B	C	D	E	Order code
20 x 20 x 14mm	101	50.5	30	24	30	84285M
20 x 20 x 16mm	101	50.5	30	26	30	84289M
26 x 26 x 16mm	108	53	36	26	36	84297M
26 x 26 x 20mm	108	53	36	30	36	84303M
32 x 32 x 16mm	108.5	53	42	26	42	84307M
32 x 32 x 20mm	108.5	53.25	42	30	42	84309M
32 x 32 x 26mm	108.5	54.25	42	36	42	84311M
40 x 40 x 26mm	108	54	50	36	50	84329M
40 x 40 x 32mm	108	54	50	42	50	84330M
50 x 50 x 26mm	154	60	60	36	60	84331M
50 x 50 x 40mm	154	60	60	50	60	84332M
63 x 63 x 26mm	171	69	73	36	73	84333M
63 x 63 x 40mm	171	70	73	50	73	84334M

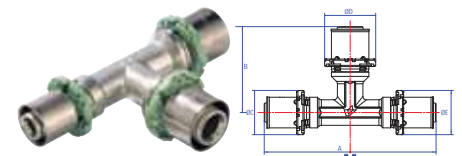

### SM26 Tee, one end reduced

Size	A	B	C	D	E	Order code
20 x 16 x 20mm	101	50.5	30	30	26	84292M
26 x 16 x 26mm	107	54	36	36	26	84304M
26 x 20 x 26mm	107	54	36	36	30	84305M
32 x 26 x 32mm	108.5	54.25	42	42	36	84312M

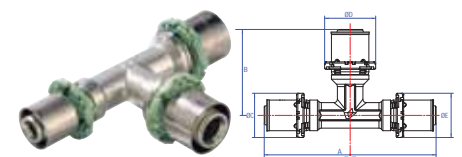

### SM27 Tee, one end and branch reduced

Size	A	B	C	D	E	Order code
16 x 14 x 14mm	88	44	26	24	24	84280M
20 x 16 x 16mm	101	50.5	30	26	26	84287M
26 x 16 x 16mm	107	53	36	26	26	84295M
26 x 16 x 20mm	107	53	36	30	26	84301M
26 x 20 x 16mm	107	53	36	26	30	84296M
26 x 20 x 20mm	107	53	36	30	30	84302M
32 x 26 x 26mm	108.5	54.25	42	36	36	84310M

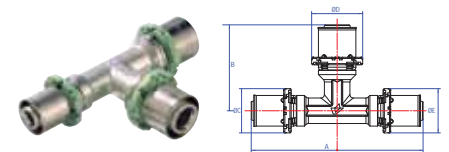

## Tee specification

See page 38

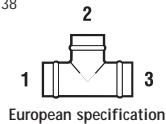
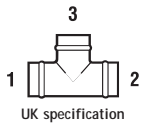

# Brass press-fit fittings

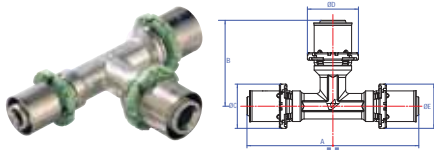

### SM28 Tee, both ends reduced

Size	A	B	C	D	E	Order code
16 x 16 x 20mm	101	50.5	26	30	26	84282M
20 x 16 x 26mm	106	54	30	36	26	84293M
20 x 20 x 26mm	106	54	30	36	30	84294M
26 x 26 x 32mm	108.5	54.25	36	42	36	84306M

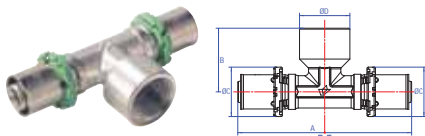

### SM30 Female branch tee

Size	A	B	C	D	Order code
16 x 16mm x 1/2"	91.5	33.5	26	26.5	84255M
20 x 20mm x 1/2"	91.5	33.5	30	26.5	84257M
20 x 20mm x 3/4"	106	42	30	33	84258M
26 x 26mm x 1/2"	108	38	36	26.5	84259M
26 x 26mm x 3/4"	108	42	36	33	84260M
26 x 26mm x 1"	108	49	36	39	84261M
32 x 32mm x 1/2"	108	40	42	26.5	84262M
32 x 32mm x 1 1/4"	118	55.5	42	48	84263M
40 x 40mm x 1"	108	51	50	39	84267M
40 x 40mm x 1 1/4"	108	55.5	50	48	84268M
50 x 50mm x 1"	108	53	60	39	84269M

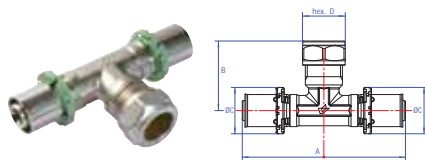

### SM30C Compression branch tee

Size	A	B	C	D	Order code
16 x 16 x 15mm	91.5	39	26	24	84320M

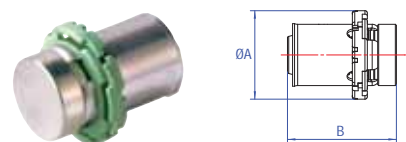

### SM61 Stop end

Size	A	B	Order code
14mm	24	32	84100M
16mm	26	32	84101M
20mm	30	32	84103M
26mm	36	34.5	84104M
32mm	42	35.5	84105M
40mm	50	36.5	84107M

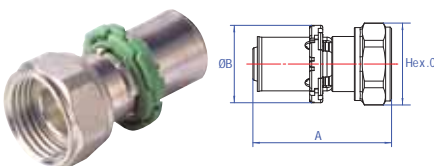

### SM62 Tap/manifold connector

Size	A	B	C	Order code
14mm x 1/2"	47	24	24	84439M
16mm x 1/2"	50	26	24	84440M
20mm x 1/2"	52.5	30	25	84441M

### SM1497 Two port manifold

Size	Order code
3/4" x 1/2"	84450M
1" x 1/2"	84451M



### SM1498 Three port manifold

Size	Code
3/4" x 1/2"	84455M
1" x 1/2"	84456M



### SM1499 Four port manifold

Size	Order code
3/4" x 1/2"	84460M
1" x 1/2"	84461M



### SM1500 Two port manifold, with ball valves and eurocone connections

Size	Colour	A	B	C	Order code
3/4" x 2 x EK14, 16, 18 and 20mm	Blue	104	55	45	84473M
3/4" x 2 x EK14, 16, 18 and 20mm	Red	104	55	45	84474M

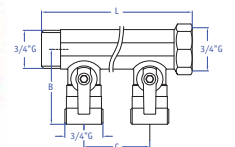

### SM1501 Three port manifold, with ball valves and eurocone connections

Size	Colour	A	B	C	Order code
3/4" x 3 x EK14, 16, 18 and 20mm	Blue	149	55	45	84475M
3/4" x 3 x EK14, 16, 18 and 20mm	Red	149	55	45	84476M

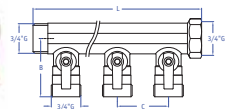

### SM1502 Four port manifold, with ball valves and eurocone connections

Size	Colour	A	B	C	Order code
3/4" x 4 x EK14, 16, 18 and 20mm	Blue	194	55	45	84477M
3/4" x 4 x EK14, 16, 18 and 20mm	Red	194	55	45	84478M

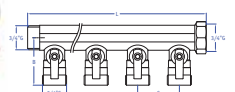

## Brass press-fit fittings

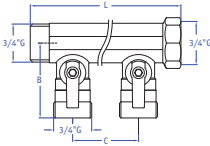

### SM1503 Two port manifold, with ball valves and eurocone connections

Size	Colour	A	B	C	Order code
1" x 2 x EK14, 16, 18 and 20mm	Blue	104	55	45	84479M
1" x 2 x EK14, 16, 18 and 20mm	Red	104	55	45	84480M

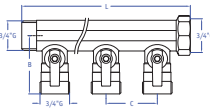

### SM1504 Three port manifold, with ball valves and eurocone connections

Size	Colour	A	B	C	Order code
1" x 3 x EK14, 16, 18 and 20mm	Blue	149	55	45	84481M
1" x 3 x EK14, 16, 18 and 20mm	Red	149	55	45	84482M

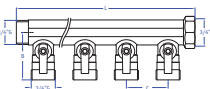

### SM1505 Four port manifold, with ball valves and eurocone connections

Size	Colour	A	B	C	Order code
1" x 4 x EK14, 16, 18 and 20mm	Blue	194	55	45	84483M
1" x 4 x EK14, 16, 18 and 20mm	Red	194	55	45	84484M



### TYPE: 2 Compression straight coupling

Size	Order code
14 x 14mm	85841
16 x 16mm	85842
20 x 20mm	85843



# Brass fittings

## TYPE: 13 Compression adaptor nickel plated

Size	Order code
14 x 15mm	85850
16 x 15mm	85851

Connection: Compression



## TYPE: 13H Compression adaptor brass

Size	Order code
16 x 15mm	85852
20 x 22mm	85853
26 x 28mm	85854

Connection: Compression



## TYPE: 24 Compression coupling

Size	Order code
16 x 15mm	85725
20 x 22mm	85726
26 x 22mm	85727
26 x 28mm	85728

Connection: Compression



## TYPE: 19P Nickel plate press-fit adaptor to Eurocone

Size	D	Order code
16mm x 3/4"	22	86141
20mm x 3/4"	26	86143

Connection: Press-fit x Eurocone

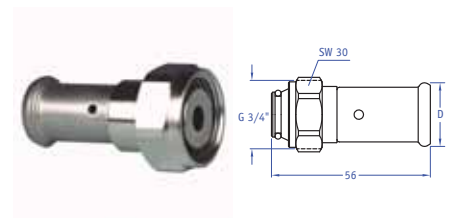

## TYPE: 29P Adaptor to copper pipe

Size	L	D1	D2	Order code
16 x 15mm	95	22	15	86150
20 x 22mm	98	26	22	86151
26 x 22mm	91	32	22	86152

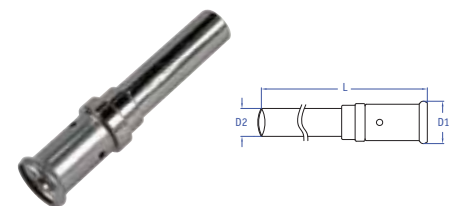

## Brass fittings

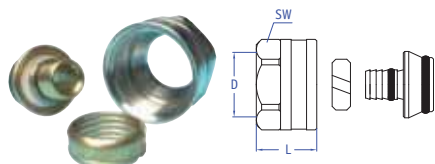

### TYPE: EK14 Eurocone nickel plated

Size	D	L	SW	Order code
14mm x 3/4"	20	15.5	26.8	85867
16mm x 3/4"	20	17.5	26.8	85869
20mm x 3/4"	23.3	21.5	26.8	85873

Connection: Eurocone

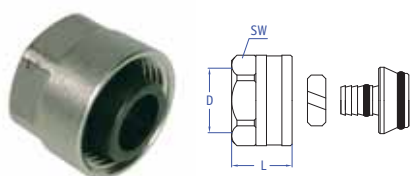

### TYPE: EK15 Eurocone for copper tube 15mm

Size	D	L	SW	Order code
15mm x 3/4"	15	22	27	85868

Connection: Eurocone



### TYPE: H94 Flexible connector with ISO valve

Size	Length	Order code
16mm x 1/2"	300mm	84470
16mm x 1/2"	600mm	84471
16mm x 3/4"	400mm	84472

Connection: Multilayer compression x union



### TYPE: H650 Kit Repair Kit

Contains	Order code
1 x KS - Kalispeed prep tool	85560
2 x Compression coupling - Cu 16 x 15mm	
2 x Compression coupling - Cu 20 x 22mm	

# Accessories and tools

## Accessories

### SM101 Pipe clips

Size	Order code
14 - 16mm	84599M
16 - 20mm	84600M
20 - 23mm	84601M
24 - 28mm	84602M
32 - 35mm	84603M
40 - 44mm	84605M
48 - 54mm	84607M
58 - 65mm	84609M

### TYPE: BP04 Black plug for 1/2" female nipple

Size	Order code
1/2"	85464



## Tools

### TYPE: BI Internal bending spring

Size	Order code
14 x 2 Length 500mm	85522
16 x 2 Length 500mm	85523
16 x 2 Length 1000mm	85526
18 x 2 Length 500mm	85524
20 x 2 Length 500mm	85525
20 x 2 Length 1000mm	85527
26 x 3 Length 1000mm	85528



### TYPE: BA External bending spring

Size	Order code
14 x 2 Length 500mm	85529
16 x 2 Length 500mm	85530
18 x 2 Length 500mm	85531
20 x 2 Length 500mm	85532



## Accessories and tools



### TYPE: BM Bending tool

Size	Order code
16mm pipe	85533
20mm pipe	85534



### TYPE: RSPRESS Guillotine cutter

Size	Order code
14-20mm pipe	85535
26-40mm pipe	85536



### TYPE: RSEM-PERS Replacement blade for RSPRESS Guillotine cutter

Size	Order code
14-20mm	85537
26-40mm	85538



### TYPE: Wheel cutter

Size	Order code
RS32 14-32mm pipe	85539
RS63 14-63mm pipe	85540



### TYPE: Replacement wheel for RS32 Wheel cutter

Size	Order code
RSEM32 14-32mm	85541
RSEM63 14-63mm	85542



### TYPE: SAFECUT Cutter to open the packing paper

Order code
85520

# Accessories and tools

## TYPE: KS-P Kalispeed prep tool

*Not for intensive use*

Size	Order code
16, 20 and 26mm	85521



## TYPE: KS-K Click handle for KS (Kalispeed)

Size	Order code
up to 40mm	85543



## TYPE: KS-M Kalispeed (metal) for KS-K and electric drills *(max. 500 rpm, clockwise only)*

Size	Order code
14mm	85544
16mm	85545
18mm	85546
20mm	85547
26mm	85548
32mm	85549
40mm	85550



## TYPE: KS Kalispeed for electric drills *(min. 13mm chuck size, max. 500 rpm, clockwise only)*

Size	Order code
50mm	85552
63mm	85553



## TYPE: KS-MSET1 Kit1 Set with KS-K and KS-M

Size	Order code
16, 20 and 26mm	85554



## TYPE: KS-MSET2 Kit2 Set with KS-K and KS-M

Size	Order code
14, 16, 18, 20, 26, 32 and 40mm	85555



## Accessories and tools



**TYPE: RRW-S Pipe straightener max 26mm**

*Order code*

85579



**TYPE: RRW-A Pipe decoiler**

*Order code*

85580



**TYPE: RRW-V Connection for RRW-S on RRW-A**

*Order code*

85581



**TYPE: RRW-1426 Pipe decoiler kit**

*Order code*

85582



**TYPE: UFH-VLA Decoiler standard**

*Order code*

85583



## Typical applications

Application	
<i>Commercial mechanical services</i>	
Drinking water	✓
Heating and cooling	✓
Rainwater	✓
Compressed air	✓
Heating oil	✓
Other	On request
<i>Domestic</i>	
Drinking water	✓
Heating and cooling	✓
Rainwater	✓
Compressed air	✓
Heating oil	✓
Other	On request

## Materials specification - Henco multilayer pipe: PE-Xc/AL/PE-Xc

Henco multilayer pipe consists of an aluminium layer (AL) with additional inner and outer layers of electron beam, cross linked polyethylene (PE-Xc).

The inner and outer layers are manufactured from high density polyethylene (HDPE) and cross linked using electron beams. Cross linking the polymer in this way increases its resistance to loads generated by internal pressure and high temperatures. A further explanation of cross linking and the electron beam method can be found later in this guide.

A continuous longitudinal butt welded joint is used to form the aluminium into a tubular reinforcing layer. This type of weld ensures an even wall thickness distribution, not only in the aluminium, but in all the layers around the pipe circumference. As a result, pressing loads are also evenly distributed which in turn provides a consistent sealing condition in the pressed joint.

The different layers are bonded to each other using a high quality adhesive. The result is a multilayer pipe with the flexibility of a

polymer combined with temperature and pressure performance associated with metals.

The aluminium layer not only gives the multilayer pipe high temperature and pressure performance and shape retaining properties, it also provides a guaranteed oxygen barrier.

The pipe meets the requirements of the strictest standards for drinking water installations and is resistant to aggressive substances.

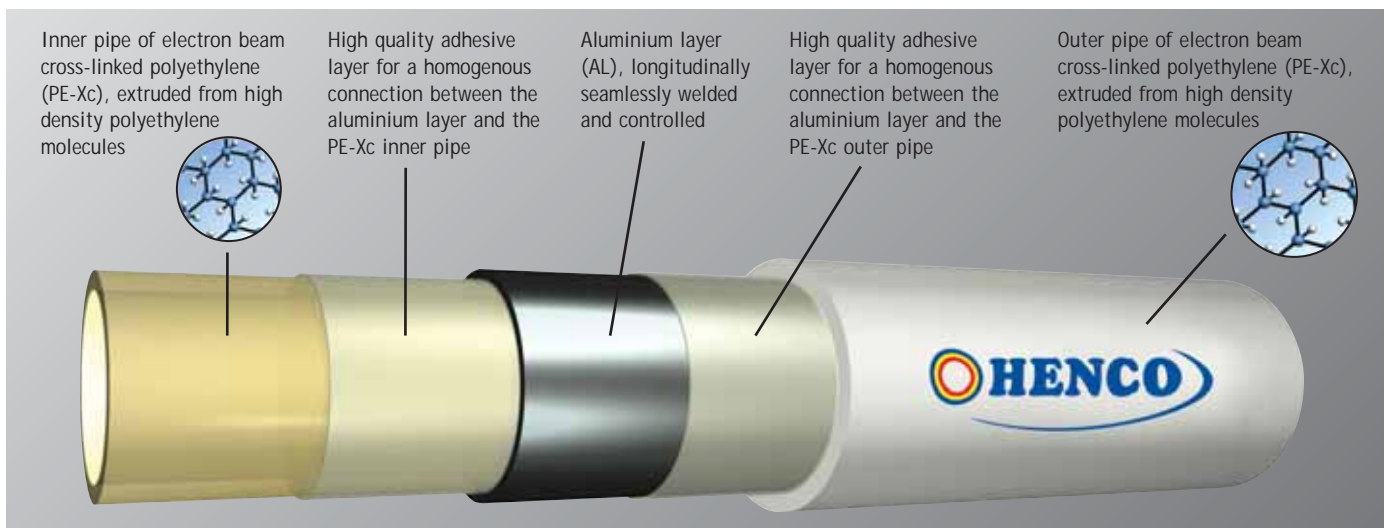

# Plastic pipe solutions Applications and manufacturing standards

## Inner and outer pipe of PE-Xc, quality assured.

PE stands for polyethylene

X stands for cross-linking

c stands for electron beam cross-linking, the process in which the polyethylene is cross-linked

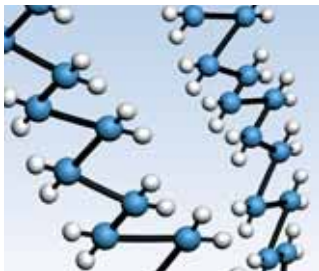

Structure of high density polyethylene

Polyethylene is a plastic that consists of different chains of molecules. These chains are not directly connected to each other. The basic structure is kept together by weak mutual forces between the molecules. When heated the chains move more vigorously and further from each other. As a result, the material becomes softer, more elastic and less pressure-resistant. Ultimately, it becomes less suitable for sanitary applications or heating.

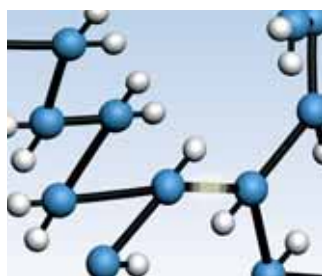
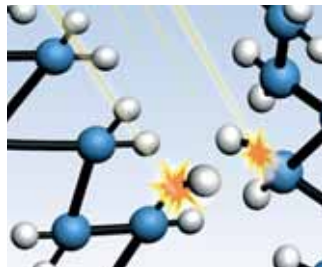

Cross-linking process by means of electron beams

Exposing the multilayer pipe to intense electron beams causes cross connections between the different molecule chains of the plastic. The electrons cause the hydrogen atoms to split from the different polyethylene chains. The carbon atoms are then allowed to join and form a strong cross-linked structure.

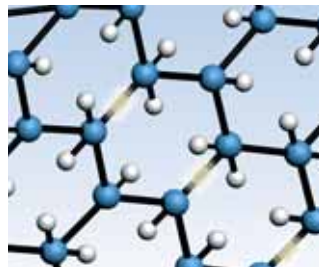

Structure of PE-Xc

The cross connections mean the movement of the chains with respect to each other is kept to a minimum. When heat or another form of energy is applied, the strong structure of the pipe will not be distorted. Cross-linked polyethylene displays optimal behaviour under continuous loads due to pressure or temperature. Cross-linking ensures enormous durability.

Cross-linking by way of electron beams is the best and purest way to cross-link polyethylene.

Polyethylene can be cross-linked in the following ways:

a. PE-Xa: the so-called Engel process, where the polyethylene is mixed with a high concentration of organic peroxide. The peroxide cause connections to take place between the polyethylene chains. A chemical method.

b. PE-Xb: cross-linking originates by the addition of silane to the polyethylene, followed by a water treatment. A chemical method.

c. PE-Xc: as distinct from the two last methods, cross-linking takes place during a second process when the pipe is exposed to intense electron beams. The beams excite the polyethylene molecules so much that they cross-link. A physical method.



## Henco multilayer pipe materials specification

TECHNICAL PROFILE OF HENCO MULTILAYER PIPE								
Outer diameter (mm)	14	16	20	26	32	40	50	63
Inner diameter (mm)	10	12	16	20	26	33	42	54
Wall thickness (mm)	2	2	2	3	3	3.5	4.0	4.5
Thickness aluminium (mm) <sup>†</sup>	0.4	0.4	0.4	0.5	0.7	0.7	0.9	1.2
Min. working temperature (°C)	-20	-20	-20	-20	-20	-20	-20	-20
Max. working temperature (°C)	95	95	95	95	95	95	95	95
Max. working pressure (bar)	10	10	10	10	10	10	10	10
Thermal conduction (W/mK)	0.43	0.43	0.43	0.43	0.43	0.43	0.43	0.43
Linear expansion (mm/mK)	0.025	0.025	0.025	0.025	0.025	0.025	0.025	0.025
Surface roughness of inner pipe (μ)	7	7	7	7	7	7	7	7
Oxygen diffusion (mg/l)	0	0	0	0	0	0	0	0
Min. bending radius manual/external spring (mm)	5xOD	5xOD	5xOD	5xOD	*	*	*	*
Min. bending radius with internal bending spring (mm)	3xOD	3xOD	3xOD	3xOD	*	*	*	*
Crosslinking/inner and outer pipe (%)	60	60	60	60	60	60	60	60
Weight (kg/m)	0.108	0.125	0.147	0.261	0.39	0.528	0.766	1.155
Water volume (l/m)	0.072	0.113	0.201	0.314	0.53	0.803	1.32	2.042
Per coil (m)	100 200	50 100	100	50	50	-	-	-
Straight lengths (m)	N/A-	3-5	3-5	3-5	3-5	3-5	3-5	3-5

<sup>†</sup>RIXc pipe has a 0.2mm aluminium layer \*necessary to use elbow fittings

### A summary of all the advantages



#### Temperature- and pressure-resistant

The working temperature may rise to 95°C, and the maximum permitted working pressure amounts to 10bar.



#### Minimum linear expansion

The presence of the aluminium layer means the coefficient of expansion of the pipe is comparable with that of copper, and 8 times less than the coefficient of expansion of an ordinary plastic pipe. The coefficient of expansion amounts to 0.025mm/mK.



#### Corrosion-resistant

The smooth surface of the pipe prevents build-up of scale or other debris. This means sedimentation and corrosion are avoided. The smoothness of the inner pipe also ensures a minimum pressure loss.



#### Shape-retaining

After bending, the pipe retains the required shape. It has no thermal memory such as other synthetic pipes. This simplifies and accelerates the installation of the pipe and can reduce the amount of fittings required.



#### Wear-resistant

The outer and inner pipe are made of electron beam cross-linked polyethylene. As a result, the pipe is not subject to wear, even at high temperatures and flow speeds.



#### Fully oxygen- and water vapour-proof (diffusion)

The integrated aluminium layer prevents the penetration of oxygen in the pipe. This means corrosion problems with any metal components in the installation are avoided.



#### Low weight (fast and simple assembly)

Fast and simple installation saves time and money. The Henco pipe is flexible and extremely light. A coil of 200m standard 16mm x 2mm pipe weighs a mere 25kg.



#### Long life

If the pipe is used according to the specified working pressure and temperature, a projected working life of at least 50 years maybe achieved.



#### No noise nuisance

As distinct from metal pipes, no noise nuisance originates due to the liquid flow if the pipe diameter is correctly selected. Contact noises can be avoided by correct assembly.



#### From drinking water to chemical liquids

The pipe complies with the most stringent toxicological and hygienic requirements. It is 100% suitable for transporting drinking water. The pipe is also resistant to various chemical liquids.

### Henco pre-insulated multilayer pipe

PE-Xc/Al/PE-Xc pipes are finished with a round or eccentric thermal insulating material. The extruded PE foam protects the pipe against

- condensation
- expansion
- heat loss
- noise transmission.

Furthermore, pipes should be protected where they are grouped at high temperatures (floor heating effect).

PE-foam has an extruded PE-film coloured red or blue. The insulating material is CFC-free and has the following characteristics:

Quality standard	UNI and ISO 9002-94
Lambda value	0.040 W/mK at + 40°C
Fire class	1 - UNI 9177 and UNI 8457
Temperature resistance	-20°C to + 95°C
Thickness (round)	6, 10 or 13 mm

### Transmission table

The adjacent table can be used when calculating the surface temperature of insulation at a given temperature difference.

$$\text{Surface Temperature of Insulation} = \text{Ambient Temperature} - (\text{Correction Value})$$

- Ambient temperature: 24°C
- Cooling water temperature: 6°C
- Temperature difference: 18°C

16mm pipe with 6mm insulation correction value 7.1°C.

Therefore the surface temperature of insulation = 24°C - 7.1°C = 16.9°C

To avoid condensation, the surface temperature of the insulation must always be higher than the dew point.

At low temperatures, where there is a risk of freezing, Pegler Yorkshire recommends the use of Glycol at a maximum concentration of 45%

Pipe Diameter	Ø14	Ø16	Ø20	Ø26	Ø32
Insulation Thickness	6mm	6mm	6mm	6mm	6mm
Temperature Difference					
0.0	0.0	0.0	0.0	0.0	0.0
1.0	0.4	0.4	0.3	0.3	0.2
2.0	0.9	0.8	0.7	0.5	0.4
3.0	1.3	1.2	1.0	0.8	0.6
4.0	1.8	1.6	1.3	0.1	0.9
5.0	2.2	2.0	1.6	1.3	1.1
6.0	2.7	2.4	2.0	1.6	1.3
7.0	3.1	2.8	2.3	1.8	1.5
8.0	3.5	3.2	2.6	2.1	1.7
9.0	4.0	3.6	2.9	2.3	1.9
10.0	4.4	4.0	3.3	2.6	2.2
11.0	4.9	4.4	3.6	2.9	2.4
12.0	5.3	4.8	3.9	3.1	2.6
13.0	5.8	5.1	4.3	3.4	2.8
14.0	6.2	5.5	4.6	3.6	3.0
15.0	6.6	5.9	4.9	3.9	3.2
16.0	7.1	6.3	5.2	4.2	3.4
17.0	7.5	6.7	5.6	4.4	3.7
18.0	8.0	7.1	5.9	4.7	3.9
19.0	8.4	7.5	6.2	4.9	4.1
20.0	8.8	7.9	6.5	5.2	4.3

## Henco multilayer pipes with protective sleeve

PE-Xc/Al/PE-Xc piping running through floors, walls or ceilings should always be protected with a sleeve. It is advisable to protect the pipes after assembly against damages caused by other work being done on the site. The protective sleeve in red, blue, yellow or black is made of polyethylene and is as pipe in pipe or separately available.

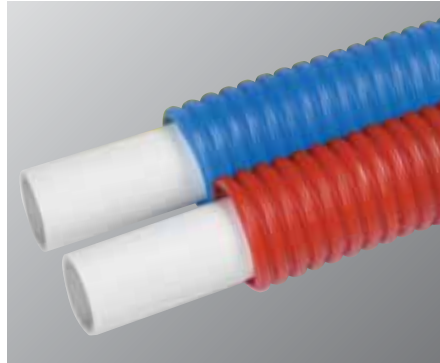

## PVDF press-fit fittings

### Composition

Henco Press Fittings are made by injection moulding PVDF (polyvinylidene fluoride). This engineering polymer offers the user a unique range of benefits:

- Excellent mechanical strength and hardness
- High wear resistance
- Flexible up to 10°
- Exceptional resistance to thermal ageing
- High purity
- No water absorption
- Excellent chemical resistance to most aggressive substances and solvents.

### Press Fitting Attributes

- PVDF body
- Viewing window – to check full pipe insertion
- Shoulder feature to locate press (BE) jaws
- Stainless steel pressure sleeve
- EPDM (ethylene propylene diene monomer) 'O' ring
- DZR (dezincification resistant) brass thread insert.

PVDF is a speciality plastic material from the fluropolymer family. It has a wide range of applications and has a proven track record of over 30 years.

Key applications include:

- *The chemical industry – because of its high resistance to aggressive substances and good thermo-mechanical properties*
- *The cable industry – because of its fire resistance and low smoke emissions*
- *The food industry – because of its purity and surface quality*
- *The plumbing industry – because of its lightweight, flexibility and elevated temperature performance.*

PVDF fittings surpass metal fitting performance in a number of ways. They are corrosion resistant, with a smooth internal bore and resist the build up of deposits. In addition, PVDF is lightweight and has low noise transmission characteristics.

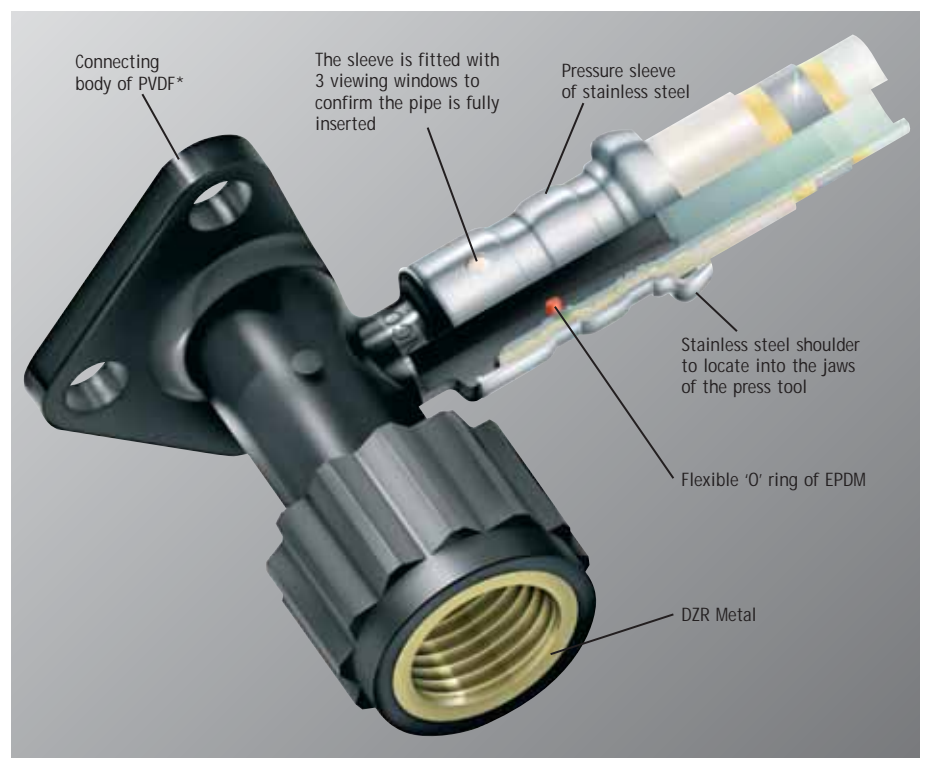

\*High quality synthetic material



### Strength and flexibility of PVDF fittings

This test was carried out in the Henco laboratory. The brackets were deliberately fixed to the sleeves of the bottom fittings to make them a fixed point.

The first photograph shows how the pipes and the fittings behave when water with a temperature of 20°C is flowing through. Nothing changes with the original test setup.

The second photograph shows how the test setup responds when water at 95°C is pumped through the piping system. The setup leans in the direction of the flow. The T-pieces and the bend fitting accommodate the expansion forces. The test shows the strength and flexibility of the Henco PVDF engineered polymer fitting.

#### Technical data

The most important PVDF data are:

Density	g/cm <sup>3</sup>	1.78
Elongation limit	MPa	54
Tensile strength	MPa	46
Elongation at rupture	%	80
Modulus of elasticity	MPa	2400
Flexural strength	MPa	74
Flexural modulus	MPa	2300
Melting point	°C	174
Thermal conductance at 23°C	W/m.K	0.19
Thermal stability	°C	380

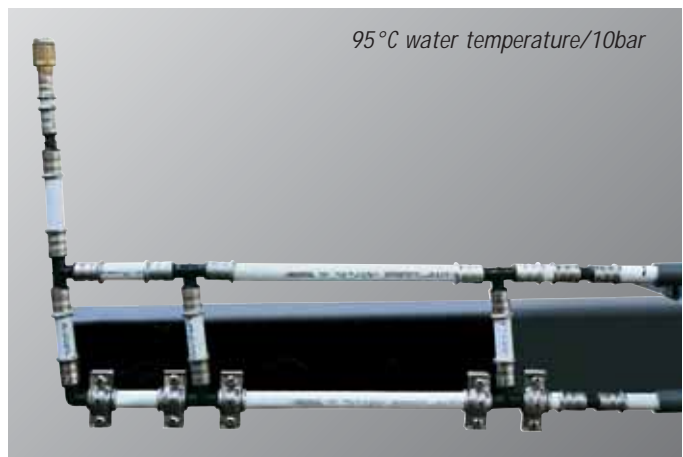
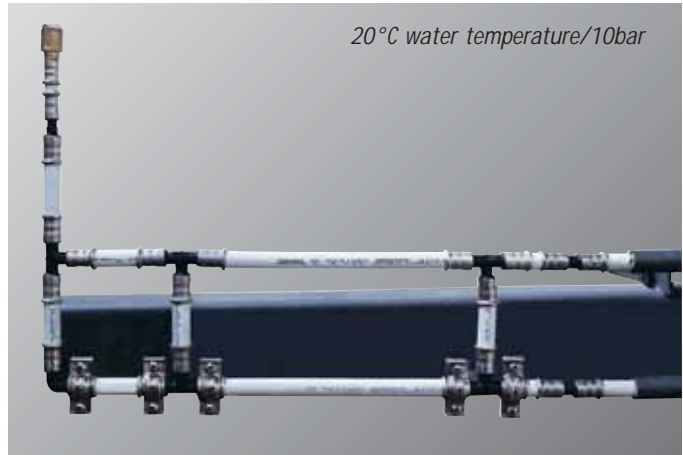

### Tee Specification

#### UK SPECIFICATION

First quote the ends on the run (larger end first) and then the branch.

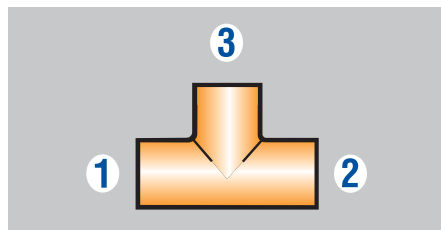

#### EUROPEAN SPECIFICATION

Quote the larger end first, then the branch, followed by the remaining end.

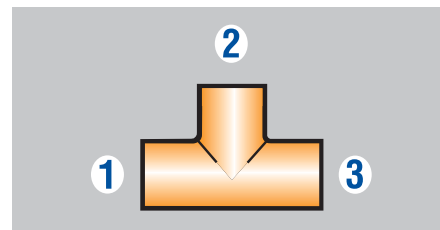



## Henco Brass with Visu-Control® System

Henco Brass has a connection system with immediate crimping proof that you can see and touch.

### Visu-Control® System

The green ring added on each connection enables easy verification of fittings which have been left uncrimped at the time of installation and before filling or pressure testing the system.

### System characteristics

- **Compatibility:** Henco Multilayer pipe with Visu-Control® is compatible with profile TH tools.
- **Crimping:** Thousands of tests carried out in the laboratory and on site confirm that the jaws of a crimp machine are not affected by using the Visu-Control® system.
- **Patent:** Visu-Control® is a patented technology.



Not crimped



Crimped



Crimped

## Fitting features

1. 'U' shaped window: allows pipe to be viewed to ensure correct installation.
2. Tinned surface: prevents corrosion in concealed installations.
3. O-ring protection: avoids any risk of damage or disjuncting when fitting the tube.
4. Easy tube connection: fittings are easily connected.
5. Dielectric protection: limits electrical current and prevents corrosion.

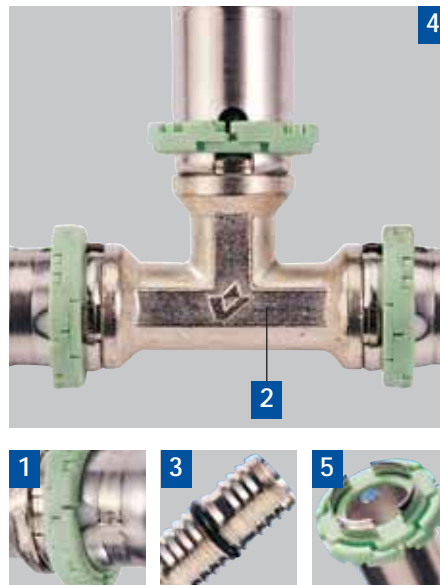

## Henco Brass range fitting specification

Henco Brass fittings with Visu-Control® are available for heating and plumbing applications, in sizes from 14 mm up to 63 mm for Henco Multilayer pipes.

Visu-Control® fittings are made according to European standards. They need to be crimped with a TH profile press tool jaw.

1. Plastic ring to maintain sleeve and to check crimping has been made.
2. EPDM O-ring DVGW Certified, according to W534.
3. Brass body according to EN 12165 and EN 12164.
4. Stainless steel ring.
5. TH crimping profile (TH L 32mm only).
6. WRAS approved up to 63mm.

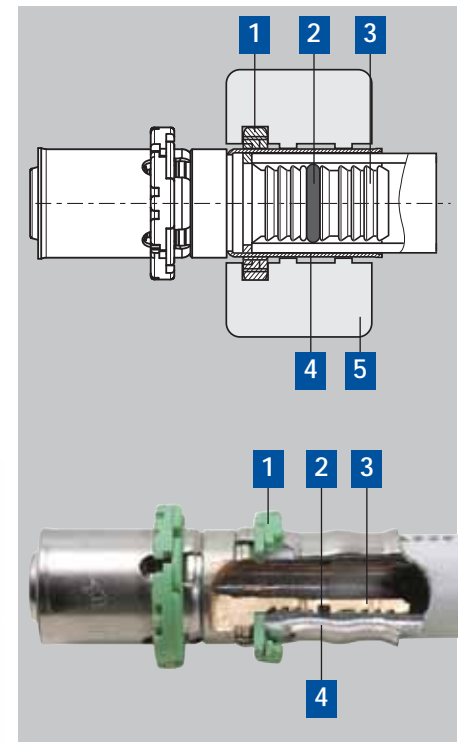

Pipe diameter (mm) Wall thickness (mm)

14	2
16	2
20	2
26	3
32	3
40	3.5
50	4
63	4.5

## Pressure loss diagram and tables

Each liquid loses energy when it flows through a pipe as a result of the force of friction of the liquid against the walls of the pipe. The diagram and tables on the following pages show the pressure loss depending on the pipe diameter and the flow speed for a given flow rate.

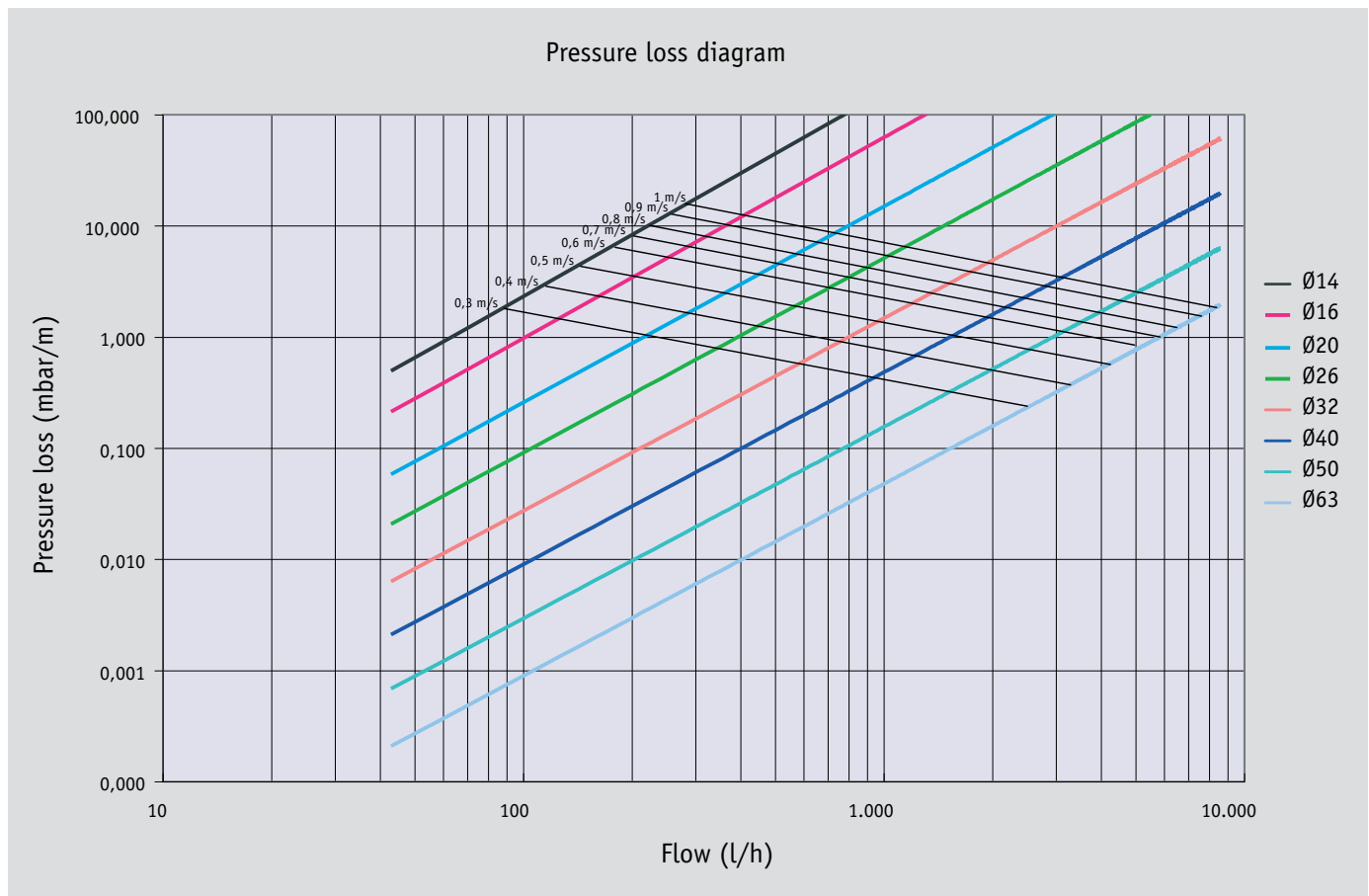

Capacity (kW/h)	Flow (l/h)	Diameter 14		Diameter 16		Diameter 20		Diameter 26		Diameter 32		Diameter 40		Diameter 50		Diameter 63	
		Speed (m/s)	Pressure loss (mbar/m)	Speed (m/s)	Pressure loss (mbar/m)	Speed (m/s)	Pressure loss (mbar/m)	Speed (m/s)	Pressure loss (mbar/m)	Speed (m/s)	Pressure loss (mbar/m)	Speed (m/s)	Pressure loss (mbar/m)	Speed (m/s)	Pressure loss (mbar/m)	Speed (m/s)	Pressure loss (mbar/m)
1	43	0.15	0.46	0.11	0.17	0.06	0.03	0.04	0.01	0.02	0.00	0.01	0.00	0.01	0.00	0.01	0.00
2	86	0.30	1.50	0.21	0.63	0.12	0.16	0.08	0.06	0.05	0.01	0.03	0.00	0.02	0.00	0.01	0.00
3	129	0.46	3.02	0.32	1.28	0.18	0.33	0.11	0.11	0.07	0.03	0.04	0.01	0.03	0.00	0.02	0.00
4	172	0.61	4.99	0.42	2.10	0.24	0.54	0.15	0.19	0.09	0.05	0.06	0.02	0.03	0.01	0.02	0.00
5	215	0.76	7.37	0.53	3.10	0.30	0.79	0.19	0.28	0.11	0.08	0.07	0.03	0.04	0.01	0.03	0.00
6	258	0.91	10.15	0.63	4.26	0.36	1.09	0.23	0.38	0.14	0.11	0.08	0.04	0.05	0.01	0.03	0.00
7	301	1.07	13.31	0.74	5.59	0.42	1.42	0.27	0.49	0.16	0.14	0.10	0.05	0.06	0.01	0.04	0.00
8	344	1.22	16.85	0.85	7.07	0.48	1.80	0.30	0.62	0.18	0.18	0.11	0.06	0.07	0.02	0.04	0.01
9	387	1.37	20.75	0.95	8.70	0.54	2.21	0.34	0.77	0.20	0.22	0.13	0.07	0.08	0.02	0.05	0.01
10	430	1.52	25.01	1.06	10.48	0.59	2.66	0.38	0.92	0.23	0.27	0.14	0.09	0.09	0.03	0.05	0.01
11	473	1.67	29.62	1.16	12.40	0.65	3.15	0.42	1.09	0.25	0.31	0.15	0.10	0.09	0.03	0.06	0.01
12	516	1.83	34.58	1.27	14.46	0.71	3.67	0.46	1.27	0.27	0.36	0.17	0.12	0.10	0.04	0.06	0.01
13	559	1.98	39.88	1.37	16.67	0.77	4.22	0.49	1.46	0.29	0.42	0.18	0.14	0.11	0.04	0.07	0.01
14	602	2.13	45.51	1.48	19.02	0.83	4.81	0.53	1.66	0.32	0.48	0.20	0.15	0.12	0.05	0.07	0.01
15	645	2.28	51.47	1.59	21.50	0.89	5.44	0.57	1.88	0.34	0.54	0.21	0.17	0.13	0.06	0.08	0.02
16	688	2.44	57.76	1.69	24.11	0.95	6.10	0.61	2.10	0.36	0.60	0.22	0.19	0.14	0.06	0.08	0.02
17	731	2.59	64.38	1.80	26.87	1.01	6.79	0.65	2.34	0.38	0.67	0.24	0.22	0.15	0.07	0.09	0.02
18	774	2.74	71.31	1.90	29.75	1.07	7.51	0.68	2.59	0.41	0.74	0.25	0.24	0.16	0.08	0.09	0.02
19	817	2.89	78.57	2.01	32.76	1.13	8.27	0.72	2.85	0.43	0.82	0.27	0.26	0.16	0.08	0.10	0.03
20	860	3.04	86.14	2.11	35.91	1.19	9.06	0.76	3.12	0.45	0.89	0.28	0.29	0.17	0.09	0.10	0.03
21	903	3.20	94.02	2.22	39.18	1.25	9.88	0.80	3.40	0.47	0.97	0.29	0.31	0.18	0.10	0.11	0.03
22	946	3.35	102.22	2.33	42.58	1.31	10.73	0.84	3.70	0.50	1.06	0.31	0.34	0.19	0.11	0.11	0.03
23	989	3.50	110.72	2.43	46.11	1.37	11.62	0.88	4.00	0.52	1.14	0.32	0.37	0.20	0.12	0.12	0.04
24	1032	3.65	119.53	2.54	49.76	1.43	12.53	0.91	4.31	0.54	1.23	0.34	0.40	0.21	0.13	0.13	0.04
25	1075	3.81	128.65	2.64	53.54	1.49	13.48	0.95	4.64	0.56	1.33	0.35	0.43	0.22	0.14	0.13	0.04
26	1118	3.96	138.07	2.75	57.44	1.55	14.45	0.99	4.97	0.59	1.42	0.36	0.46	0.22	0.14	0.14	0.04
27	1161	4.11	147.79	2.85	61.47	1.61	15.46	1.03	5.32	0.61	1.52	0.38	0.49	0.23	0.15	0.14	0.05
28	1204	4.26	157.81	2.96	65.62	1.66	16.50	1.07	5.67	0.63	1.62	0.39	0.52	0.24	0.16	0.15	0.05
29	1247	4.41	168.13	3.07	69.89	1.72	17.57	1.10	6.04	0.65	1.72	0.41	0.55	0.25	0.18	0.15	0.05
30	1290	4.57	178.75	3.17	74.29	1.78	18.67	1.14	6.41	0.68	1.83	0.42	0.59	0.26	0.19	0.16	0.06
31	1333	4.72	189.66	3.28	78.80	1.84	19.79	1.18	6.80	0.70	1.94	0.43	0.62	0.27	0.20	0.16	0.06
32	1376	4.87	200.87	3.38	83.44	1.90	20.95	1.22	7.19	0.72	2.05	0.45	0.66	0.28	0.21	0.17	0.06
33	1419	5.02	212.37	3.49	88.19	1.96	22.14	1.26	7.60	0.74	2.17	0.46	0.69	0.28	0.22	0.17	0.07
34	1462	5.18	224.16	3.59	93.07	2.02	23.35	1.29	8.01	0.77	2.29	0.48	0.73	0.29	0.23	0.18	0.07
35	1505	5.33	236.24	3.70	98.06	2.08	24.60	1.33	8.44	0.79	2.41	0.49	0.77	0.30	0.24	0.18	0.07
36	1548	5.48	248.61	3.81	103.17	2.14	25.87	1.37	8.88	0.81	2.53	0.50	0.81	0.31	0.26	0.19	0.08
37	1591	5.63	261.27	3.91	108.40	2.20	27.18	1.41	9.32	0.83	2.66	0.52	0.85	0.32	0.27	0.19	0.08
38	1634	5.78	274.22	4.02	113.75	2.26	28.51	1.45	9.78	0.86	2.79	0.53	0.89	0.33	0.28	0.20	0.09
39	1677	5.94	287.46	4.12	119.21	2.32	29.87	1.48	10.24	0.88	2.92	0.55	0.93	0.34	0.30	0.20	0.09
40	1720	6.09	300.98	4.23	124.79	2.38	31.26	1.52	10.71	0.90	3.05	0.56	0.98	0.35	0.31	0.21	0.09
41	1763	6.24	314.78	4.33	130.49	2.44	32.68	1.56	11.20	0.92	3.19	0.57	1.02	0.35	0.32	0.21	0.10
42	1806	6.39	328.87	4.44	136.30	2.50	34.12	1.60	11.69	0.95	3.33	0.59	1.07	0.36	0.34	0.22	0.10
43	1849	6.55	343.25	4.55	142.23	2.56	35.60	1.64	12.20	0.97	3.47	0.60	1.11	0.37	0.35	0.22	0.11
44	1892	6.70	357.90	4.65	148.27	2.62	37.10	1.67	12.71	0.99	3.62	0.62	1.16	0.38	0.37	0.23	0.11
45	1935	6.85	372.84	4.76	154.43	2.68	38.63	1.71	13.23	1.01	3.76	0.63	1.20	0.39	0.38	0.23	0.11
46	1978	7.00	388.06	4.86	160.70	2.74	40.19	1.75	13.76	1.04	3.91	0.64	1.25	0.40	0.40	0.24	0.12
47	2021	7.15	403.56	4.97	167.09	2.79	41.78	1.79	14.30	1.06	4.07	0.66	1.30	0.41	0.41	0.25	0.12
48	2064	7.31	419.33	5.07	173.59	2.85	43.39	1.83	14.85	1.08	4.22	0.67	1.35	0.41	0.43	0.25	0.13
49	2107	7.46	435.39	5.18	180.20	2.91	45.03	1.86	15.41	1.10	4.38	0.68	1.40	0.42	0.44	0.26	0.13
50	2150	7.61	451.72	5.29	186.93	2.97	46.70	1.90	15.98	1.13	4.54	0.70	1.45	0.43	0.46	0.26	0.14

Medium: water at 70°C AT=20°

$P = Q \times AT \times 1,163$   
= capacity in Watt

1 mbar/m = 100 Pa/m

Capacity (kW/h)	Diameter 14		Diameter 16		Diameter 20		Diameter 26		Diameter 32		Diameter 40		Diameter 50		Diameter 63		
	Flow (l/h)	Speed (m/s)	Pressure loss (mbar/m)	Speed (m/s)	Pressure loss (mbar/m)	Speed (m/s)	Pressure loss (mbar/m)	Speed (m/s)	Pressure loss (mbar/m)	Speed (m/s)	Pressure loss (mbar/m)	Speed (m/s)	Pressure loss (mbar/m)	Speed (m/s)	Pressure loss (mbar/m)	Speed (m/s)	Pressure loss (mbar/m)
51	2193	7.76	468.34	5.39	193.77	3.03	48.40	1.94	16.56	1.15	4.71	0.71	1.50	0.44	0.48	0.27	0.14
52	2236	7.92	485.22	5.50	200.72	3.09	50.12	1.98	17.15	1.17	4.87	0.73	1.56	0.45	0.49	0.27	0.15
53	2279	8.07	502.39	5.60	207.78	3.15	51.87	2.02	17.74	1.19	5.04	0.74	1.61	0.46	0.51	0.28	0.15
54	2322	8.22	519.83	5.71	214.96	3.21	53.65	2.05	18.35	1.22	5.21	0.75	1.67	0.47	0.53	0.28	0.16
55	2365	8.37	537.55	5.81	222.25	3.27	55.46	2.09	18.96	1.24	5.39	0.77	1.72	0.47	0.54	0.29	0.16
56	2408	8.52	555.54	5.92	229.65	3.33	57.29	2.13	19.59	1.26	5.56	0.78	1.78	0.48	0.56	0.29	0.17
57	2451	8.68	573.80	6.03	237.16	3.39	59.15	2.17	20.22	1.28	5.74	0.80	1.83	0.49	0.58	0.30	0.17
58	2494	8.83	592.34	6.13	244.78	3.45	61.04	2.21	20.86	1.31	5.92	0.81	1.89	0.50	0.60	0.30	0.18
59	2537	8.98	611.15	6.24	252.51	3.51	62.96	2.25	21.52	1.33	6.11	0.82	1.95	0.51	0.62	0.31	0.19
60	2580	9.13	630.23	6.34	260.35	3.57	64.90	2.28	22.18	1.35	6.29	0.84	2.01	0.52	0.63	0.31	0.19
61	2623	9.29	649.58	6.45	268.30	3.63	66.87	2.32	22.85	1.37	6.48	0.85	2.07	0.53	0.65	0.32	0.20
62	2666	9.44	669.21	6.55	276.37	3.69	68.86	2.36	23.52	1.40	6.68	0.87	2.13	0.54	0.67	0.32	0.20
63	2709	9.59	689.11	6.66	284.54	3.75	70.88	2.40	24.21	1.42	6.87	0.88	2.19	0.54	0.69	0.33	0.21
64	2752	9.74	709.28	6.77	292.82	3.81	72.93	2.44	24.91	1.44	7.07	0.89	2.25	0.55	0.71	0.33	0.21
65	2795	9.89	729.71	6.87	301.21	3.86	75.01	2.47	25.61	1.46	7.27	0.91	2.32	0.56	0.73	0.34	0.22
66	2838	10.05	750.42	6.98	309.71	3.92	77.11	2.51	26.33	1.49	7.47	0.92	2.38	0.57	0.75	0.34	0.23
67	2881	10.20	771.40	7.08	318.32	3.98	79.24	2.55	27.05	1.51	7.67	0.94	2.45	0.58	0.77	0.35	0.23
68	2924	10.35	792.65	7.19	327.04	4.04	81.39	2.59	27.78	1.53	7.88	0.95	2.51	0.59	0.79	0.35	0.24
70	3010	10.66	835.94	7.40	344.80	4.16	85.78	2.66	29.27	1.58	8.30	0.98	2.65	0.60	0.83	0.37	0.25
71	3053	10.81	857.99	7.51	353.85	4.22	88.01	2.70	30.03	1.60	8.51	0.99	2.71	0.61	0.86	0.37	0.26
72	3096	10.96	880.31	7.61	363.00	4.28	90.27	2.74	30.80	1.62	8.73	1.01	2.78	0.62	0.88	0.38	0.26
73	3139	11.11	902.90	7.72	372.26	4.34	92.56	2.78	31.58	1.64	8.95	1.02	2.85	0.63	0.90	0.38	0.27
74	3182	11.26	925.75	7.82	381.63	4.40	94.87	2.82	32.36	1.67	9.17	1.03	2.92	0.64	0.92	0.39	0.28
75	3225	11.42	948.87	7.93	391.10	4.46	97.21	2.85	33.15	1.69	9.39	1.05	2.99	0.65	0.94	0.39	0.28
76	3268	11.57	972.25	8.03	400.68	4.52	99.57	2.89	33.96	1.71	9.62	1.06	3.07	0.66	0.97	0.40	0.29
77	3311	11.72	995.90	8.14	410.37	4.58	101.96	2.93	34.77	1.73	9.85	1.08	3.14	0.66	0.99	0.40	0.30
78	3354	11.87	1019.82	8.25	420.17	4.64	104.38	2.97	35.59	1.76	10.08	1.09	3.21	0.67	1.01	0.41	0.30
79	3397	12.03	1044.00	8.35	430.07	4.70	106.82	3.01	36.42	1.78	10.31	1.10	3.29	0.68	1.04	0.41	0.31
80	3440	12.18	1068.44	8.46	440.08	4.76	109.28	3.04	37.25	1.80	10.55	1.12	3.36	0.69	1.06	0.42	0.32
81	3483	12.33	1093.15	8.56	450.20	4.82	111.78	3.08	38.10	1.82	10.79	1.13	3.44	0.70	1.08	0.42	0.33
82	3526	12.48	1118.13	8.67	460.43	4.88	114.30	3.12	38.95	1.85	11.03	1.15	3.51	0.71	1.11	0.43	0.33
83	3569	12.63	1143.36	8.77	470.76	4.94	116.84	3.16	39.82	1.87	11.27	1.16	3.59	0.72	1.13	0.43	0.34
84	3612	12.79	1168.86	8.88	481.19	4.99	119.41	3.20	40.69	1.89	11.52	1.17	3.67	0.72	1.16	0.44	0.35
85	3655	12.94	1194.63	8.99	491.74	5.05	122.01	3.23	41.57	1.91	11.76	1.19	3.75	0.73	1.18	0.44	0.35
86	3698	13.09	1220.66	9.09	502.38	5.11	124.63	3.27	42.46	1.94	12.01	1.20	3.83	0.74	1.20	0.45	0.36
87	3741	13.24	1246.95	9.20	513.14	5.17	127.27	3.31	43.35	1.96	12.27	1.22	3.91	0.75	1.23	0.45	0.37
88	3784	13.40	1273.50	9.30	524.00	5.23	129.95	3.35	44.26	1.98	12.52	1.23	3.99	0.76	1.26	0.46	0.38
89	3827	13.55	1300.31	9.41	534.97	5.29	132.65	3.39	45.17	2.00	12.78	1.24	4.07	0.77	1.28	0.46	0.38
90	3870	13.70	1327.39	9.51	546.04	5.35	135.37	3.42	46.10	2.03	13.04	1.26	4.15	0.78	1.31	0.47	0.39
91	3913	13.85	1354.73	9.62	557.21	5.41	138.12	3.46	47.03	2.05	13.30	1.27	4.23	0.79	1.33	0.48	0.40
92	3956	14.00	1382.33	9.73	568.50	5.47	140.89	3.50	47.97	2.07	13.57	1.29	4.32	0.79	1.36	0.48	0.41
93	3999	14.16	1410.19	9.83	579.88	5.53	143.69	3.54	48.92	2.09	13.83	1.30	4.40	0.80	1.39	0.49	0.42
94	4042	14.31	1438.31	9.94	591.38	5.59	146.52	3.58	49.87	2.12	14.10	1.31	4.49	0.81	1.41	0.49	0.42
95	4085	14.46	1466.69	10.04	602.97	5.65	149.37	3.62	50.84	2.14	14.37	1.33	4.57	0.82	1.44	0.50	0.43
96	4128	14.61	1495.34	10.15	614.67	5.71	152.24	3.65	51.81	2.16	14.65	1.34	4.66	0.83	1.47	0.50	0.44
97	4171	14.77	1524.24	10.25	626.48	5.77	155.14	3.69	52.79	2.18	14.92	1.36	4.75	0.84	1.49	0.51	0.45
98	4214	14.92	1553.41	10.36	638.39	5.83	158.07	3.73	53.78	2.21	15.20	1.37	4.84	0.85	1.52	0.51	0.46
99	4257	15.07	1582.83	10.47	650.41	5.89	161.02	3.77	54.78	2.23	15.48	1.38	4.92	0.85	1.55	0.52	0.47
100	4300	15.22	1612.51	10.57	662.53	5.95	163.99	3.81	55.79	2.25	15.77	1.40	5.01	0.86	1.58	0.52	0.47
101	4343	15.37	1642.45	10.68	674.75	6.01	166.99	3.84	56.80	2.27	16.05	1.41	5.11	0.87	1.61	0.53	0.48

Medium: water at 70°C

AT=20°

$P = Q \times AT \times 1,163$   
= capacity in Watt

1 mbar/m = 100 Pa/m

Capacity (kW/h)	Flow (l/h)	Diameter 14		Diameter 16		Diameter 20		Diameter 26		Diameter 32		Diameter 40		Diameter 50		Diameter 63	
		Speed (m/s)	Pressure loss (mbar/m)	Speed (m/s)	Pressure loss (mbar/m)	Speed (m/s)	Pressure loss (mbar/m)	Speed (m/s)	Pressure loss (mbar/m)	Speed (m/s)	Pressure loss (mbar/m)	Speed (m/s)	Pressure loss (mbar/m)	Speed (m/s)	Pressure loss (mbar/m)	Speed (m/s)	Pressure loss (mbar/m)
102	4386	15.53	1672.66	10.78	687.08	6.07	170.02	3.88	57.83	2.30	16.34	1.43	5.20	0.88	1.63	0.53	0.49
103	4429	15.68	1703.12	10.89	699.51	6.12	173.07	3.92	58.86	2.32	16.63	1.44	5.29	0.89	1.66	0.54	0.50
104	4472	15.83	1733.84	10.99	712.05	6.18	176.15	3.96	59.90	2.34	16.92	1.45	5.38	0.90	1.69	0.54	0.51
105	4515	15.98	1764.82	11.10	724.69	6.24	179.25	4.00	60.95	2.36	17.22	1.47	5.47	0.91	1.72	0.55	0.52
106	4558	16.14	1796.05	11.21	737.44	6.30	182.37	4.03	62.01	2.39	17.51	1.48	5.57	0.91	1.75	0.55	0.53
107	4601	16.29	1827.55	11.31	750.28	6.36	185.52	4.07	63.07	2.41	17.81	1.50	5.66	0.92	1.78	0.56	0.53
108	4644	16.44	1859.30	11.42	763.24	6.42	188.70	4.11	64.15	2.43	18.11	1.51	5.76	0.93	1.81	0.56	0.54
109	4687	16.59	1891.31	11.52	776.29	6.48	191.90	4.15	65.23	2.45	18.42	1.52	5.85	0.94	1.84	0.57	0.55
110	4730	16.74	1923.58	11.63	789.45	6.54	195.12	4.19	66.32	2.48	18.72	1.54	5.95	0.95	1.87	0.57	0.56
111	4773	16.90	1956.11	11.73	802.71	6.60	198.37	4.22	67.42	2.50	19.03	1.55	6.05	0.96	1.90	0.58	0.57
112	4816	17.05	1988.89	11.84	816.08	6.66	201.65	4.26	68.53	2.52	19.34	1.57	6.15	0.97	1.93	0.58	0.58
113	4859	17.20	2021.93	11.95	829.54	6.72	204.95	4.30	69.64	2.54	19.66	1.58	6.25	0.98	1.96	0.59	0.59
114	4902	17.35	2055.23	12.05	843.12	6.78	208.27	4.34	70.76	2.57	19.97	1.59	6.35	0.98	2.00	0.60	0.60
115	4945	17.51	2088.79	12.16	856.79	6.84	211.62	4.38	71.90	2.59	20.29	1.61	6.45	0.99	2.03	0.60	0.61
116	4988	17.66	2122.60	12.26	870.57	6.90	215.00	4.41	73.04	2.61	20.61	1.62	6.55	1.00	2.06	0.61	0.62
117	5031	17.81	2156.67	12.37	884.45	6.96	218.39	4.45	74.18	2.63	20.93	1.64	6.65	1.01	2.09	0.61	0.63
118	5074	17.96	2190.99	12.47	898.43	7.02	221.82	4.49	75.34	2.66	21.26	1.65	6.75	1.02	2.12	0.62	0.64
119	5117	18.11	2225.57	12.58	912.52	7.08	225.26	4.53	76.50	2.68	21.58	1.66	6.86	1.03	2.15	0.62	0.65
120	5160	18.27	2260.41	12.69	926.70	7.14	228.74	4.57	77.68	2.70	21.91	1.68	6.96	1.04	2.19	0.63	0.66
121	5203	18.42	2295.50	12.79	940.99	7.19	232.23	4.60	78.86	2.72	22.24	1.69	7.07	1.04	2.22	0.63	0.67
122	5246	18.57	2330.85	12.90	955.39	7.25	235.75	4.64	80.05	2.75	22.58	1.71	7.17	1.05	2.25	0.64	0.68
123	5289	18.72	2366.46	13.00	969.88	7.31	239.30	4.68	81.24	2.77	22.91	1.72	7.28	1.06	2.29	0.64	0.69
124	5332	18.88	2402.32	13.11	984.48	7.37	242.87	4.72	82.45	2.79	23.25	1.73	7.38	1.07	2.32	0.65	0.70
125	5375	19.03	2438.43	13.21	999.18	7.43	246.46	4.76	83.66	2.81	23.59	1.75	7.49	1.08	2.35	0.65	0.71
126	5418	19.18	2474.80	13.32	1013.98	7.49	250.08	4.79	84.88	2.84	23.93	1.76	7.60	1.09	2.39	0.66	0.72
127	5461	19.33	2511.43	13.42	1028.89	7.55	253.72	4.83	86.11	2.86	24.28	1.78	7.71	1.10	2.42	0.66	0.73
128	5504	19.48	2548.31	13.53	1043.89	7.61	257.39	4.87	87.35	2.88	24.63	1.79	7.82	1.10	2.46	0.67	0.74
129	5547	19.64	2585.44	13.64	1059.00	7.67	261.08	4.91	88.60	2.90	24.98	1.80	7.93	1.11	2.49	0.67	0.75
130	5590	19.79	2622.83	13.74	1074.21	7.73	264.80	4.95	89.85	2.93	25.33	1.82	8.04	1.12	2.53	0.68	0.76
131	5633	19.94	2660.48	13.85	1089.52	7.79	268.54	4.99	91.11	2.95	25.68	1.83	8.15	1.13	2.56	0.68	0.77
132	5676	20.09	2698.37	13.95	1104.94	7.85	272.30	5.02	92.38	2.97	26.04	1.85	8.26	1.14	2.60	0.69	0.78
133	5719	20.25	2736.53	14.06	1120.45	7.91	276.09	5.06	93.66	2.99	26.40	1.86	8.38	1.15	2.63	0.69	0.79
134	5762	20.40	2774.93	14.16	1136.07	7.97	279.91	5.10	94.95	3.02	26.76	1.87	8.49	1.16	2.67	0.70	0.80
135	5805	20.55	2813.60	14.27	1151.79	8.03	283.74	5.14	96.24	3.04	27.12	1.89	8.61	1.16	2.70	0.70	0.81
136	5848	20.70	2852.51	14.38	1167.61	8.09	287.61	5.18	97.54	3.06	27.48	1.90	8.72	1.17	2.74	0.71	0.82
137	5891	20.85	2891.68	14.48	1183.53	8.15	291.49	5.21	98.85	3.08	27.85	1.91	8.84	1.18	2.77	0.72	0.83
138	5934	21.01	2931.10	14.59	1199.55	8.21	295.40	5.25	100.17	3.11	28.22	1.93	8.95	1.19	2.81	0.72	0.84
139	5977	21.16	2970.78	14.69	1215.68	8.27	299.34	5.29	101.50	3.13	28.59	1.94	9.07	1.20	2.85	0.73	0.85
140	6020	21.31	3010.71	14.80	1231.90	8.32	303.29	5.33	102.83	3.15	28.97	1.96	9.19	1.21	2.88	0.73	0.86
141	6063	21.46	3050.89	14.90	1248.23	8.38	307.28	5.37	104.18	3.18	29.34	1.97	9.31	1.22	2.92	0.74	0.88
142	6106	21.62	3091.32	15.01	1264.66	8.44	311.28	5.40	105.53	3.20	29.72	1.98	9.43	1.23	2.96	0.74	0.89
143	6149	21.77	3132.01	15.12	1281.19	8.50	315.31	5.44	106.89	3.22	30.10	2.00	9.55	1.23	3.00	0.75	0.90
144	6192	21.92	3172.96	15.22	1297.82	8.56	319.37	5.48	108.25	3.24	30.48	2.01	9.67	1.24	3.03	0.75	0.91
145	6235	22.07	3214.15	15.33	1314.55	8.62	323.45	5.52	109.63	3.27	30.87	2.03	9.79	1.25	3.07	0.76	0.92
146	6278	22.22	3255.60	15.43	1331.38	8.68	327.55	5.56	111.01	3.29	31.25	2.04	9.91	1.26	3.11	0.76	0.93
147	6321	22.38	3297.30	15.54	1348.31	8.74	331.68	5.59	112.40	3.31	31.64	2.05	10.04	1.27	3.15	0.77	0.94
148	6364	22.53	3339.25	15.64	1365.34	8.80	335.83	5.63	113.80	3.33	32.04	2.07	10.16	1.28	3.19	0.77	0.95
149	6407	22.68	3381.45	15.75	1382.48	8.86	340.00	5.67	115.20	3.36	32.43	2.08	10.28	1.29	3.23	0.78	0.97
150	6450	22.83	3423.91	15.86	1399.71	8.92	344.20	5.71	116.62	3.38	32.82	2.10	10.41	1.29	3.27	0.78	0.98
151	6493	22.99	3466.62	15.96	1417.05	8.98	348.43	5.75	118.04	3.40	33.22	2.11	10.53	1.30	3.31	0.79	0.99

Medium: water at 70°C AT=20° P = Q x AT x 1,163  
= capacity in Watt

1 mbar/m = 100 Pa/m



Capacity (kW/h)	Flow (l/h)	Diameter 14		Diameter 16		Diameter 20		Diameter 26		Diameter 32		Diameter 40		Diameter 50		Diameter 63	
		Speed (m/s)	Pressure loss (mbar/m)	Speed (m/s)	Pressure loss (mbar/m)	Speed (m/s)	Pressure loss (mbar/m)	Speed (m/s)	Pressure loss (mbar/m)	Speed (m/s)	Pressure loss (mbar/m)	Speed (m/s)	Pressure loss (mbar/m)	Speed (m/s)	Pressure loss (mbar/m)	Speed (m/s)	Pressure loss (mbar/m)
152	6536	23.14	3509.58	16.07	1434.49	9.04	352.67	5.78	119.47	3.42	33.62	2.12	10.66	1.31	3.34	0.79	1.00
153	6579	23.29	3552.80	16.17	1452.02	9.10	356.94	5.82	120.91	3.45	34.03	2.14	10.79	1.32	3.38	0.80	1.01
154	6622	23.44	3596.26	16.28	1469.66	9.16	361.24	5.86	122.35	3.47	34.43	2.15	10.92	1.33	3.42	0.80	1.03
155	6665	23.59	3639.98	16.38	1487.40	9.22	365.56	5.90	123.81	3.49	34.84	2.17	11.04	1.34	3.46	0.81	1.04
156	6708	23.75	3683.95	16.49	1505.23	9.28	369.90	5.94	125.27	3.51	35.25	2.18	11.17	1.35	3.50	0.81	1.05
157	6751	23.90	3728.17	16.60	1523.17	9.34	374.26	5.97	126.74	3.54	35.66	2.19	11.30	1.35	3.55	0.82	1.06
158	6794	24.05	3772.64	16.70	1541.21	9.39	378.65	6.01	128.22	3.56	36.07	2.21	11.43	1.36	3.59	0.82	1.07
159	6837	24.20	3817.37	16.81	1559.35	9.45	383.07	6.05	129.70	3.58	36.49	2.22	11.56	1.37	3.63	0.83	1.09
160	6880	24.36	3862.34	16.91	1577.59	9.51	387.50	6.09	131.20	3.60	36.90	2.24	11.70	1.38	3.67	0.84	1.10
161	6923	24.51	3907.57	17.02	1595.93	9.57	391.97	6.13	132.70	3.63	37.32	2.25	11.83	1.39	3.71	0.84	1.11
162	6966	24.66	3953.05	17.12	1614.37	9.63	396.45	6.16	134.21	3.65	37.75	2.26	11.96	1.40	3.75	0.85	1.12
163	7009	24.81	3998.77	17.23	1632.91	9.69	400.96	6.20	135.72	3.67	38.17	2.28	12.10	1.41	3.79	0.85	1.14
164	7052	24.96	4044.75	17.34	1651.55	9.75	405.49	6.24	137.25	3.69	38.60	2.29	12.23	1.42	3.84	0.86	1.15
165	7095	25.12	4090.99	17.44	1670.29	9.81	410.05	6.28	138.78	3.72	39.02	2.31	12.37	1.42	3.88	0.86	1.16
166	7138	25.27	4137.47	17.55	1689.13	9.87	414.63	6.32	140.32	3.74	39.45	2.32	12.50	1.43	3.92	0.87	1.17
167	7181	25.42	4184.20	17.65	1708.06	9.93	419.23	6.36	141.87	3.76	39.89	2.33	12.64	1.44	3.96	0.87	1.19
168	7224	25.57	4231.18	17.76	1727.10	9.99	423.86	6.39	143.43	3.78	40.32	2.35	12.78	1.45	4.01	0.88	1.20
169	7267	25.73	4278.42	17.86	1746.24	10.05	428.51	6.43	144.99	3.81	40.76	2.36	12.91	1.46	4.05	0.88	1.21
170	7310	25.88	4325.90	17.97	1765.48	10.11	433.19	6.47	146.56	3.83	41.20	2.38	13.05	1.47	4.09	0.89	1.22
171	7353	26.03	4373.63	18.08	1784.82	10.17	437.88	6.51	148.14	3.85	41.64	2.39	13.19	1.48	4.14	0.89	1.24
172	7396	26.18	4421.62	18.18	1804.26	10.23	442.61	6.55	149.73	3.87	42.08	2.40	13.33	1.48	4.18	0.90	1.25
173	7439	26.33	4469.85	18.29	1823.80	10.29	447.35	6.58	151.33	3.90	42.53	2.42	13.47	1.49	4.22	0.90	1.26
174	7482	26.49	4518.34	18.39	1843.43	10.35	452.12	6.62	152.93	3.92	42.98	2.43	13.61	1.50	4.27	0.91	1.28
175	7525	26.64	4567.08	18.50	1863.17	10.41	456.91	6.66	154.54	3.94	43.43	2.45	13.75	1.51	4.31	0.91	1.29
176	7568	26.79	4616.06	18.60	1883.01	10.47	461.73	6.70	156.16	3.96	43.88	2.46	13.90	1.52	4.36	0.92	1.30
177	7611	26.94	4665.30	18.71	1902.94	10.52	466.57	6.74	157.79	3.99	44.33	2.47	14.04	1.53	4.40	0.92	1.32
178	7654	27.10	4714.78	18.82	1922.98	10.58	471.43	6.77	159.42	4.01	44.79	2.49	14.18	1.54	4.45	0.93	1.33
179	7697	27.25	4764.52	18.92	1943.11	10.64	476.32	6.81	161.06	4.03	45.25	2.50	14.33	1.54	4.49	0.93	1.34
180	7740	27.40	4814.50	19.03	1963.34	10.70	481.23	6.85	162.71	4.05	45.71	2.52	14.47	1.55	4.54	0.94	1.36
181	7783	27.55	4864.74	19.13	1983.68	10.76	486.16	6.89	164.37	4.08	46.17	2.53	14.62	1.56	4.58	0.94	1.37
182	7826	27.70	4915.22	19.24	2004.11	10.82	491.12	6.93	166.04	4.10	46.64	2.54	14.77	1.57	4.63	0.95	1.38
183	7869	27.86	4965.96	19.34	2024.64	10.88	496.10	6.96	167.71	4.12	47.11	2.56	14.91	1.58	4.67	0.96	1.40
184	7912	28.01	5016.94	19.45	2045.27	10.94	501.11	7.00	169.39	4.14	47.57	2.57	15.06	1.59	4.72	0.96	1.41
185	7955	28.16	5068.17	19.56	2066.00	11.00	506.14	7.04	171.08	4.17	48.05	2.59	15.21	1.60	4.77	0.97	1.43
186	7998	28.31	5119.65	19.66	2086.83	11.06	511.19	7.08	172.78	4.19	48.52	2.60	15.36	1.61	4.81	0.97	1.44
187	8041	28.47	5171.38	19.77	2107.76	11.12	516.26	7.12	174.48	4.21	49.00	2.61	15.51	1.61	4.86	0.98	1.45
188	8084	28.62	5223.37	19.87	2128.79	11.18	521.36	7.15	176.19	4.23	49.47	2.63	15.66	1.62	4.91	0.98	1.47
189	8127	28.77	5275.60	19.98	2149.91	11.24	526.48	7.19	177.91	4.26	49.95	2.64	15.81	1.63	4.95	0.99	1.48
190	8170	28.92	5328.07	20.08	2171.14	11.30	531.63	7.23	179.64	4.28	50.44	2.66	15.96	1.64	5.00	0.99	1.50
191	8213	29.07	5380.80	20.19	2192.46	11.36	536.80	7.27	181.38	4.30	50.92	2.67	16.12	1.65	5.05	1.00	1.51
192	8256	29.23	5433.78	20.30	2213.89	11.42	541.99	7.31	183.12	4.32	51.41	2.68	16.27	1.66	5.10	1.00	1.52
193	8299	29.38	5487.00	20.40	2235.41	11.48	547.20	7.34	184.87	4.35	51.89	2.70	16.42	1.67	5.14	1.01	1.54
194	8342	29.53	5540.48	20.51	2257.03	11.54	552.44	7.38	186.63	4.37	52.38	2.71	16.58	1.67	5.19	1.01	1.55
195	8385	29.68	5594.20	20.61	2278.75	11.59	557.70	7.42	188.39	4.39	52.88	2.73	16.73	1.68	5.24	1.02	1.57
196	8428	29.84	5648.17	20.72	2300.57	11.65	562.99	7.46	190.17	4.41	53.37	2.74	16.89	1.69	5.29	1.02	1.58
197	8471	29.99	5702.39	20.82	2322.49	11.71	568.30	7.50	191.95	4.44	53.87	2.75	17.04	1.70	5.34	1.03	1.60
198	8514	30.14	5756.86	20.93	2344.50	11.77	573.63	7.53	193.74	4.46	54.37	2.77	17.20	1.71	5.39	1.03	1.61
199	8557	30.29	5811.58	21.04	2366.62	11.83	578.98	7.57	195.54	4.48	54.87	2.78	17.36	1.72	5.44	1.04	1.63
200	8600	30.44	5866.55	21.14	2388.83	11.89	584.36	7.61	197.34	4.50	55.37	2.80	17.52	1.73	5.49	1.04	1.64

Medium: water at 70°C

AT=20°

$P = Q \times AT \times 1,163$   
= capacity in Watt

1 mbar/m = 100 Pa/m



## Flow loss coefficients (Zeta values)

In addition to losing energy when it flows through a pipe, liquid also loses energy when it changes direction. The liquid must then overcome extra resistance. The table below gives an overview of the flow loss coefficients of the different auxiliary parts and the corresponding number of metres of piping.

AUXILIARY PARTS			ZETA VALUES								
			Ø14	Ø16	Ø18	Ø20	Ø26	Ø32	Ø40	Ø50	Ø63
Curved bend			1.50	1.25	1.10	1.85	0.70	-	-	-	-
90° bend			4.20	3.40	2.80	2.05	1.40	1.00	0.80	0.55	0.50
90° T-piece	T-piece flow separator		5.20	4.45	3.85	3.20	1.70	1.20	0.85	0.70	0.65
	T-piece passage		4.00	3.05	2.25	1.35	0.85	0.55	0.40	0.35	0.30
	T-piece up cut with flow separator		4.30	4.15	3.10	1.95	1.50	1.10	0.90	0.75	0.70
	T-piece up cut with flow joint		4.30	4.15	3.10	1.95	1.50	1.10	0.90	0.75	0.70
Wall plate			3.25	2.80	2.55	2.15	1.30	-	-	-	-
Transition reduction			4.20	3.40	2.80	2.05	1.40	1.00	0.80	0.55	0.50
Fitting	(straight connector)		2.50	2.00	1.50	0.95	0.35	0.25	0.20	0.20	0.10

AUXILIARY PARTS			EQUIVALENT PIPE LENGTH/M								
			Ø14	Ø16	Ø18	Ø20	Ø26	Ø32	Ø40	Ø50	Ø63
Curved bend			0.74	0.65	0.61	0.50	0.49	-	-	-	-
90° bend			1.65	1.50	1.35	1.20	1.10	1.00	1.20	1.20	1.30
90° T-piece	T-piece flow separator		1.65	1.60	1.55	1.50	1.45	1.35	1.30	1.30	1.40
	T-piece passage		1.60	1.30	1.00	0.70	0.75	0.60	0.60	0.70	0.70
	T-piece up cut with flow separator		1.90	1.70	1.50	1.30	1.25	1.20	1.40	1.40	1.50
	T-piece up cut with flow joint		1.90	1.70	1.50	1.30	1.25	1.20	1.40	1.40	1.50
Wall plate			1.28	1.30	1.33	1.35	1.10	-	-	-	-
Transition reduction			1.65	1.50	1.35	1.20	1.10	1.00	1.20	1.20	1.30
Fitting	(straight connector)		1.05	0.90	0.75	0.60	0.30	0.25	0.30	0.40	0.30

### Expansion table

Pipework systems expand and contract with changes in temperature. If the pipework/fittings are fixed too rigidly and their movement restricted, the installation will be subject to stress. Stress concentrations between 'fixed points' – typically found at radiators, valves and other fittings – should be avoided.

The expansion table is drawn up based on the formula:

$$AL = L \times \alpha \times AT$$

With:

- AL = change in length
- L = pipe length
- $\alpha$  = coefficient of expansion
- AT = temperature difference

Where the coefficient of expansion amounts to 0.025mm/mK irrespective of the diameter of the pipe.

#### Example:

Given: L = 8 m  
 $\alpha$  = 0.025mm/mK  
 AT = 50°C (at Tmin=20°C and Tmax=70°C)

Asked: AL

Solution: Consult the expansion table or apply the formula.

Table: AL = 10.0mm

Formula:  $AL = L \times \alpha \times AT$   
 $AL = 8 \times 0.025 \times 50$   
 AL = 10.0mm

The expansion of the pipe must be considered when designing an installation.

EXPANSION (MM/M)	TEMPERATURE DIFFERENCE (AT)								
	Pipe length (m)	10°C	20°C	30°C	40°C	50°C	60°C	70°C	80°C
1		0.25	0.50	0.75	1.00	1.25	1.50	1.75	2.00
2		0.50	1.00	1.50	2.00	2.50	3.00	3.50	4.00
3		0.75	1.50	2.25	3.00	3.75	4.50	5.25	6.00
4		1.00	2.00	3.00	4.00	5.00	6.00	7.00	8.00
5		1.25	2.50	3.75	5.00	6.25	7.50	8.75	10.00
6		1.50	3.00	4.50	6.00	7.50	9.00	10.50	12.00
7		1.75	3.50	5.25	7.00	8.75	10.50	12.25	14.00
8		2.00	4.00	6.00	8.00	10.00	12.00	14.00	16.00
9		2.25	4.50	6.75	9.00	11.25	13.50	15.75	18.00
10		2.50	5.00	7.50	10.00	12.50	15.00	17.50	20.00

### Pressure Equipment Directive

Since 30th May 2002 most pressure equipment and assemblies on the market in the United Kingdom have had to comply with the Pressure Equipment Directive (P.E.D.) 1999.

Fittings are exempt from the P.E.D. unless they are incorporated into pressure equipment, meaning that all Henco fittings are exempt.

For a detailed explanation please visit: [www.peglyorkshire.co.uk/technical.cfm](http://www.peglyorkshire.co.uk/technical.cfm)

### Heat Expansion

#### Example of heat expansion

Expansion comparisons from 20°C to 50°C ( $\Delta = 30°C$  for a 10m length of pipe.)

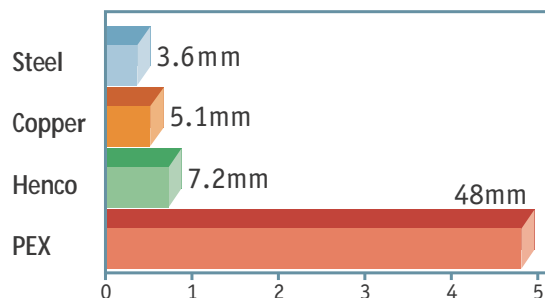

## Expansion of Henco pipe

### Within a building

To accommodate the expansion of the pipe within the structure, you must provide insulated expansion bends at least every 10m prior to burying the pipe.

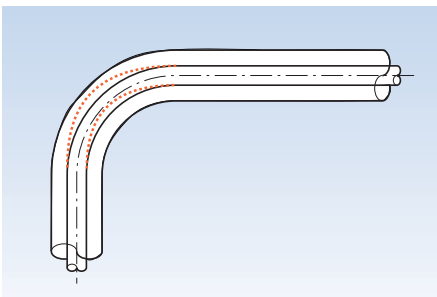

We recommend the pipes have a protective sleeve, or better still, insulation.

The sleeve has a protective function, while the insulation not only protects and thermally insulates the pipe, it also prevents the formation of condensation.

To determine the insulation thickness you can apply the following rule:  $1.5 \times \Delta L$  (change in length).

When Henco pipe is to be used for underfloor heating, these conditions do not apply.

Henco pipe must be secured at least every 2m using a pipe bracket.

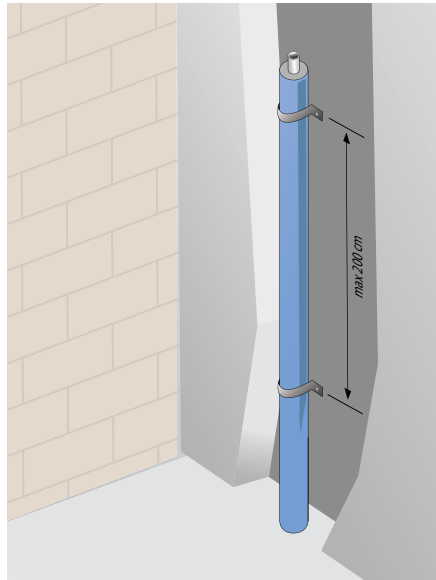

### Surface mounting

For surface mounting, pipes are available in straight lengths. Pipe brackets must be used when fixing Henco multilayer pipes to the wall or ceiling. The suspension brackets are synthetic or metal with a synthetic ring for the protection of the pipe. The specified maximum distance between the brackets must be adhered to. The adjacent table gives an overview of the bracket distances required.

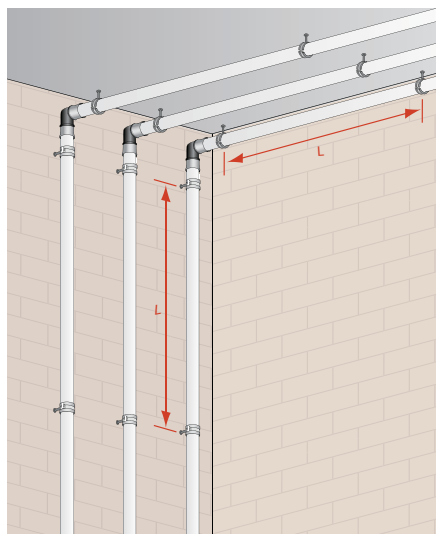

MAX. DISTANCE PIPE BRACKETS (CM)

Pipe	Distance
14 x 2	80
16 x 2	80
20 x 2	120
26 x 3	150
32 x 3	160
40 x 3.5	170
50 x 4	180
63 x 4.5	200

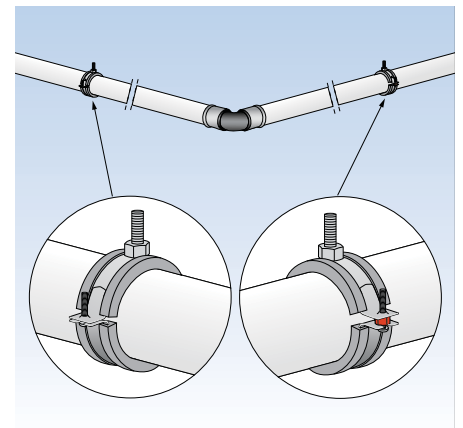

### Thermal movement

Thermal movement is a major consideration when designing and installing plumbing and heating systems and should be taken into account.

The pipe brackets serve two functions; firstly they support the pipe network, and secondly they accommodate the thermal movement. The sliding points must allow for clearance. The sliding point should not become a fixed point when the pipe expands.

# Plastic pipe solutions

## System design considerations

The correct placing of sliding points and fixed points is very important when expansion bends and expansion loops are used. At all changes in direction expansion bends must be provided.

For making direction changes it is recommended to always use fittings. For pipes with a diameter of 32mm or greater this is compulsory.

- L = length of the pipe
- L<sub>b</sub> = length of the expansion bend
- AL = change in
- F = fixed point
- GL = sliding point
- Expansion bend for r L (L<sub>b</sub>)

Where a long pipe does not change direction expansion loops are required. An expansion loop is also called a lyra or omega bend. The drawing opposite clarifies what an expansion loop is.

The expansion loop is in principle formed by two expansion bends. A fixed point must therefore be provided at the bottom in the middle of the loop.

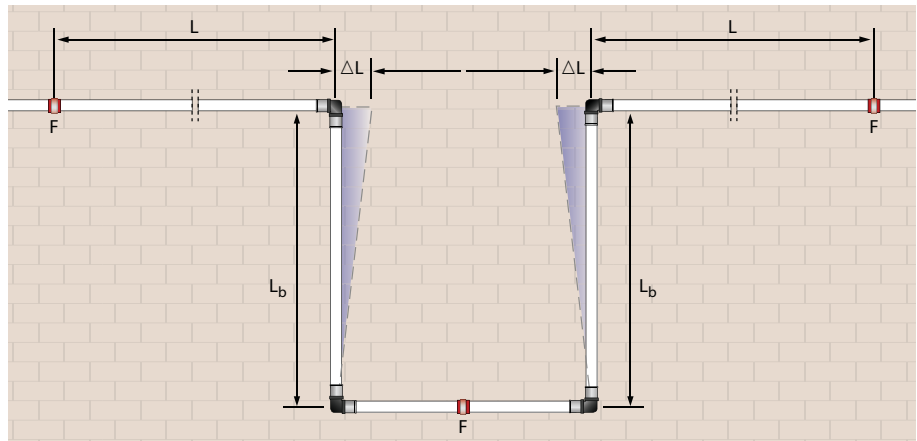
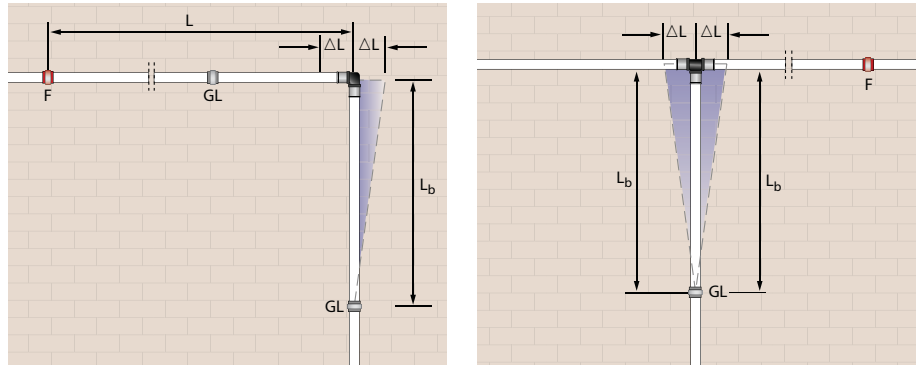

The minimum length of the expansion bend can be calculated on the basis of the following formula or read from the diagram below:

$$L_b = C \times s(D \times AL)$$

with: L<sub>b</sub> = length of the expansion bend  
 C = material constant (=33)  
 D = outside diameter of the pipe  
 AL = change in length

Example:

Given: L = 4m  
 D = 26mm  
 AT = 50°C (T<sub>min</sub>=10°C  
 en T<sub>max</sub>= 60°C)

Asked: L<sub>b</sub>

Solution: L<sub>b</sub> = C x s(D x AL)

with AL = L x α x AT  
 = 4 x 0.025 x 50  
 = 5mm

L<sub>b</sub> = C x s(D x AL)  
 = 33 x s26 x 5  
 = 376.25mm

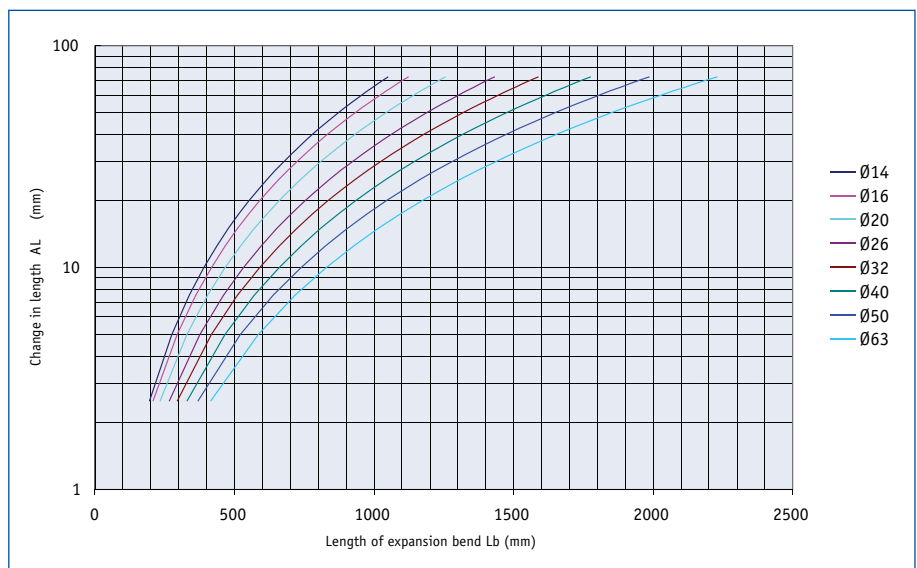

For a pipe with a diameter of 26mm and a length of 4m that has a change of direction, with a temperature difference of 50°C an expansion bend of 376.25mm will have to be provided to accommodate the change in length.

## Covered pipework

It is vital that pipes can move freely when piping runs from floors to a riser pipe in a shaft. The change in length can be accommodated by an expansion bend and the upward and downward movements.

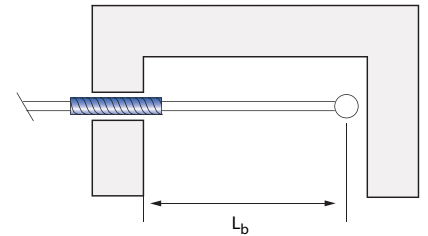
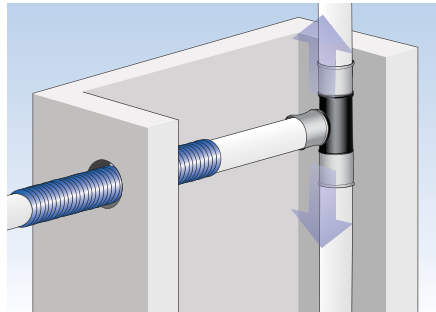

If the shaft is large enough and there is space to fit the calculated expansion bend, ensure the pipe has a protective sleeve when passing through brick, blockwork or plaster.

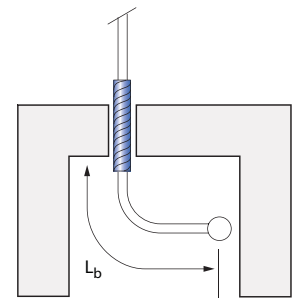
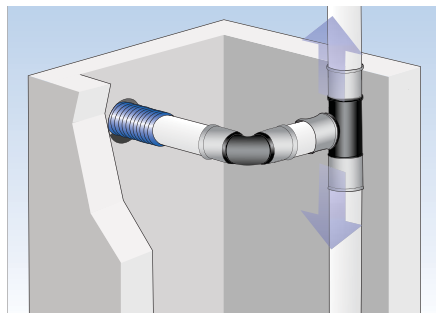

If the shaft is too small to fit the calculated expansion bend, the hole in the wall will have to be made larger to accommodate pipe, PE insulation and movement.

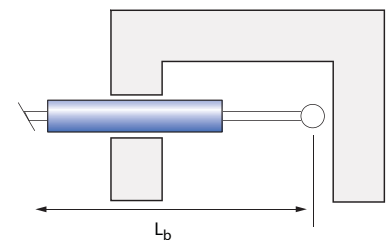
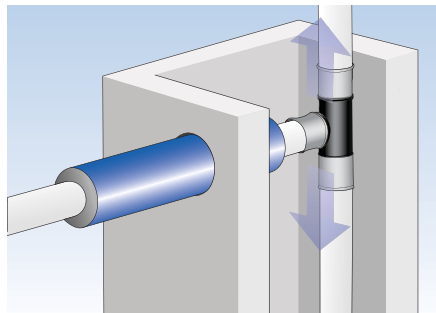

For installations where Henco multilayer pipes are laid straight on to the floor, the fixing distance applies at 80cm. Before and after a 90° bend, fixing pipe brackets must be at 30cm.

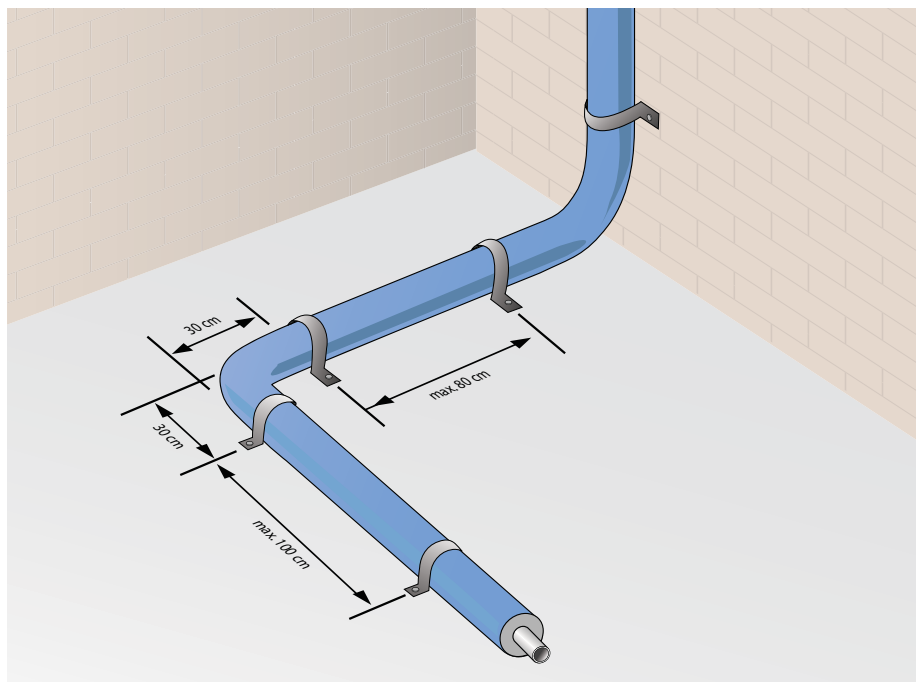

If the riser pipe is longer than 10m a fixed point must always be provided. We recommend to have this point in the middle of the pipe because the expansion forces generated will be smaller.

The drawings show that the total length of the expansion bends required is lower when a fixed point is placed in the middle of the riser pipe, when compared to placing it at the start of the riser pipe.

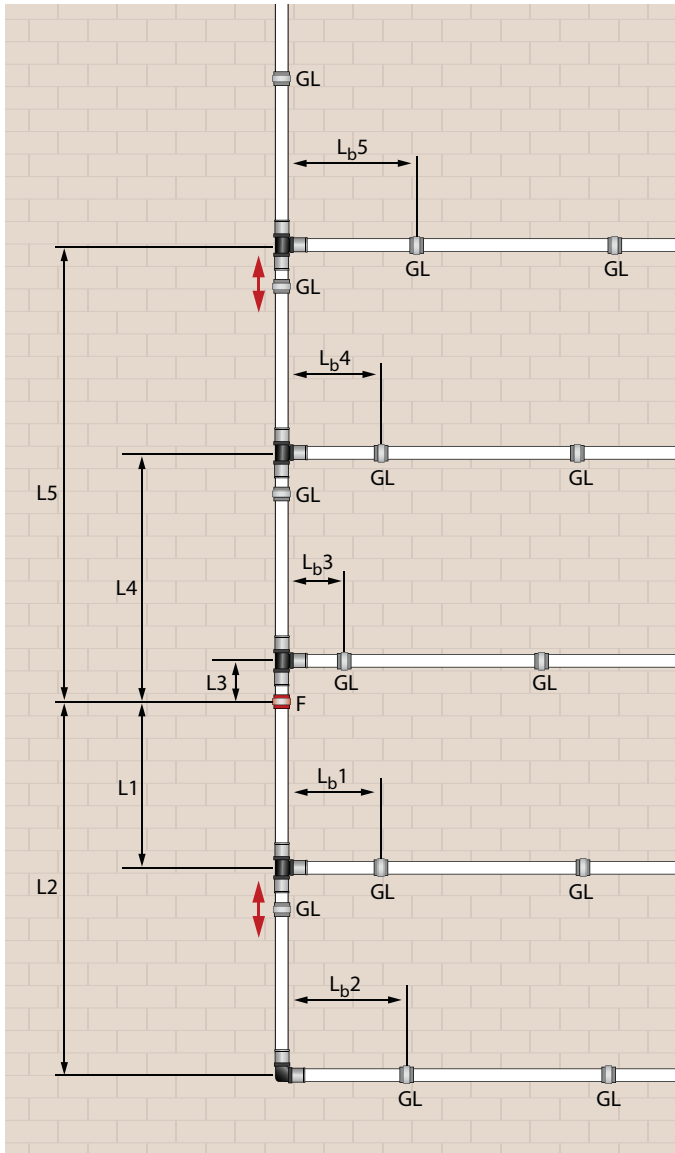

$L_{b1} + L_{b2} + L_{b3} + L_{b4} + L_{b5}$

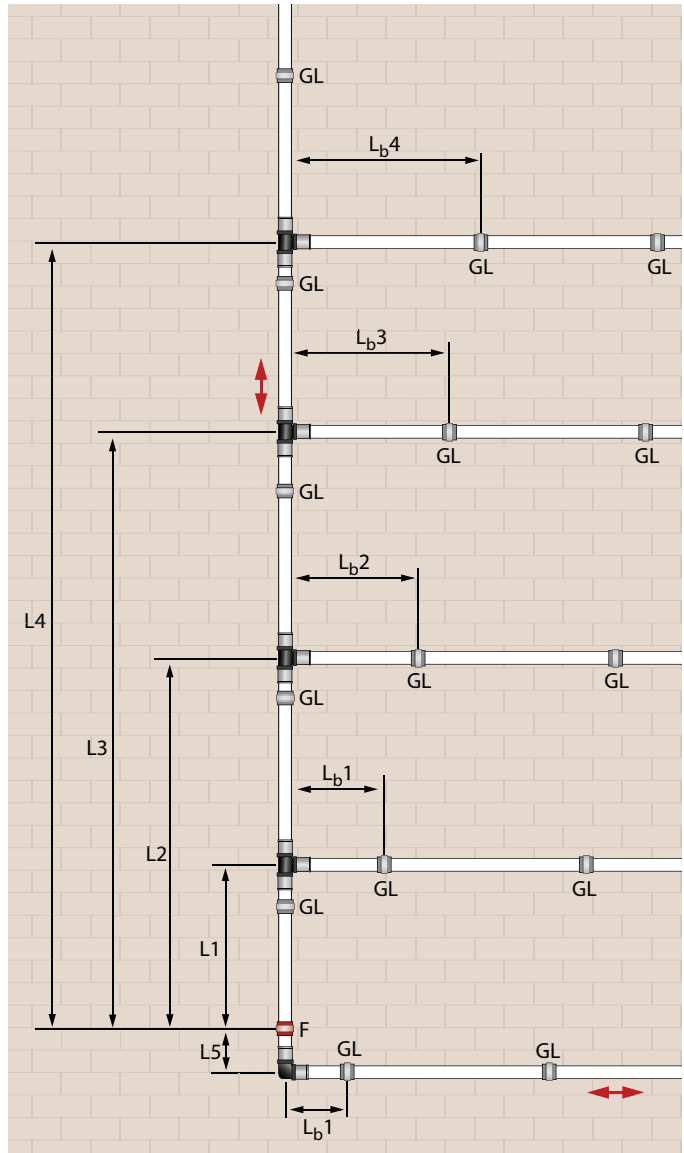

$L_{b1} + L_{b2} + L_{b3} + L_{b4} + L_{b5}$

<

Types and dimensions of pre-insulated pipes: see pages 9 and 10.



## Flush mounted fittings

The metal parts of the flush mounted fittings must be protected against corrosion. This can be by means of easily accessible, waterproof built-in boxes, tape-sealed protective sleeve, or a tape-sealed encasing of a synthetic cellular material.

The materials used for this must not affect neither the pipe nor the fitting.

## Pipes through joists and ceilings

The preferred practice is to pass pipes through sleeve or conduits avoiding sharp edges/corners and kinking.

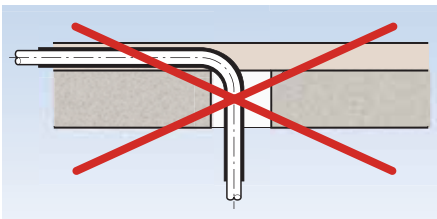
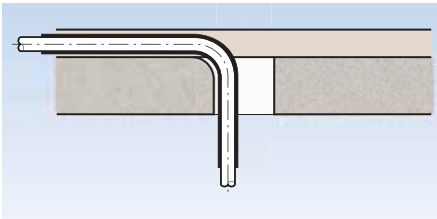

## Pipes in danger zones

When laying Henco multilayer pipes in zones subject to aggressive gases (stables, etc.) or permanently penetrating humidity (industrial kitchens, swimming pools, etc.), it is necessary to protect the metal connections. This can be by means including the use of appropriate anti-rust strips or heat-shrinking materials according to DIN 1988/7.

## Pipe insulation

If alternative insulation materials are used, we strongly recommend advice is sought from the insulation manufacturer and to ensure the adhesives used do not contain products that are harmful to the pipe or fittings, even if no direct contact is made. We also recommend you adhere to the insulation requirements as specified by the water supply (water fittings) Regulations 1999.

## Frost protection and trace heating

The system is suitable for the use of trace heating. The aluminium pipe guarantees equal heat transfer over the whole area of the pipe. The fastening of the additional heating to the pipe takes place at normal indoor temperatures using cables or self-adhesive tape. Consult Pegler Yorkshire when use is made of self-adhesive tape for the fastening of the trace heating to the pipe, or for better heat distribution. Trace heating must be technically approved. With the use of additional heating the temperature of the drinking water may not be higher than 60°C.

It must be ensured that additional heating is switched off for water that is not circulating.

## Disinfection and chlorination

The producer must be consulted beforehand in the case of the use of disinfecting products or the application of a thermal cycle with temperatures higher than the specified temperature for use.

## Equipotential bonding

Systems using Henco pipe and fittings do not provide electrical continuity.

## Local water authority

We recommend you consult the local water authority when it comes to pipework accessibility.

## Building in dimensions

All building in dimensions are correct at the time of going to press. Pegler Yorkshire reserves the right to change these dimensions without prior notice, however to ensure you are using the most up to date information please refer to our web site [www.pegleryorkshire.co.uk](http://www.pegleryorkshire.co.uk)



## Regression curve (working life)

The working life of the multilayer pipe depends on the temperature and pressure in the pipe. The straight lines in the diagram show which pressure the pipe can resist at a certain age and a constant water temperature.

It is clear that the pipe can withstand less pressure as it becomes older. To obtain DVGW certification, after 50 years and a constant water temperature of 70°C a pipe must be able to withstand a pressure 1.5 times greater than the working pressure. A regression curve is diameter-dependent.

The regression curves for the different diameters of the multilayer pipe show that with any diameter, after 50 years with a water temperature of 70°C, a pressure can be resisted that is much higher than that required for DVGW certification. The pipe has a projected working life of at least 50 years.

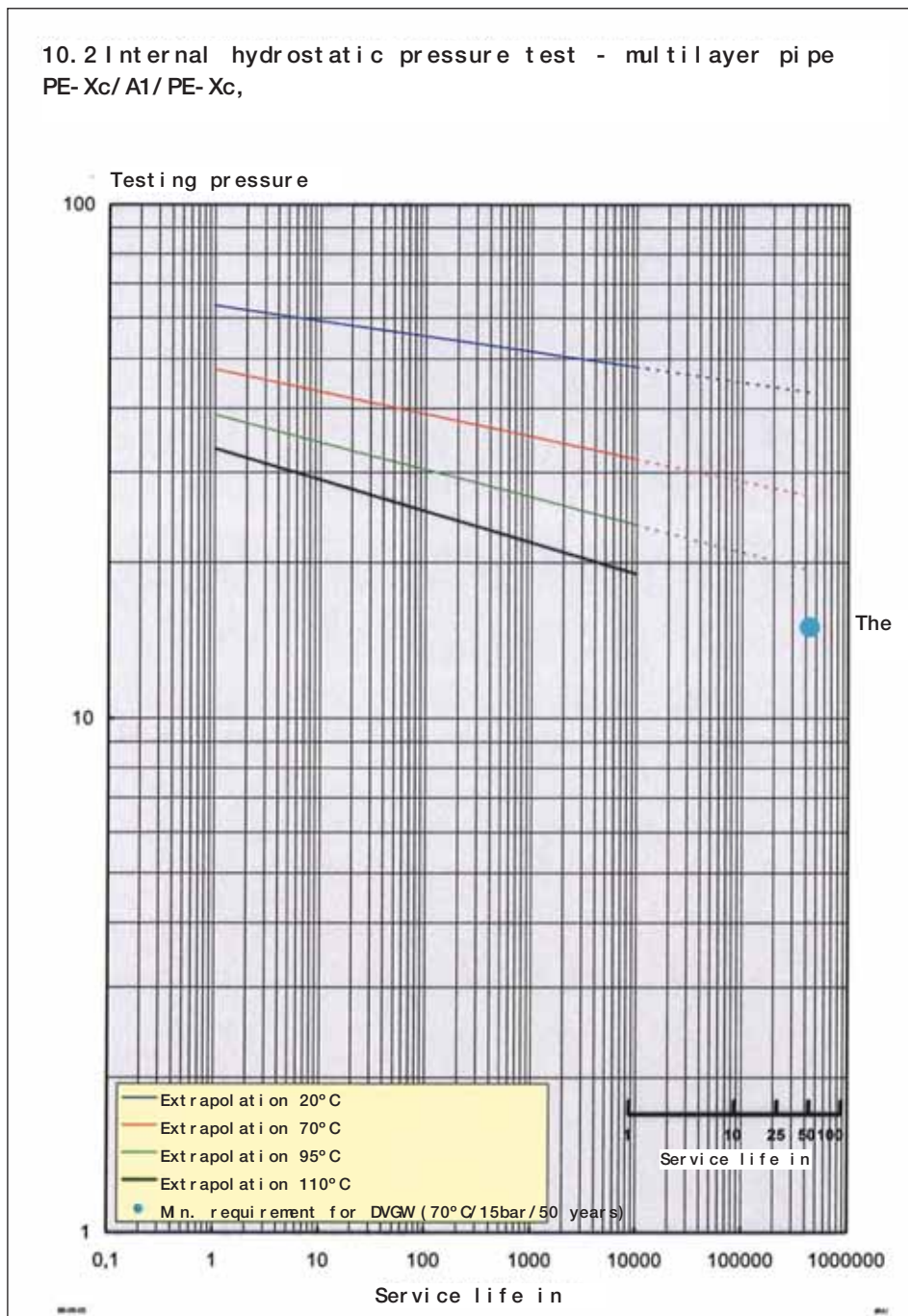

### General instructions for installing the pipe

- The pipes must be transported and stored with care in the original manufacturer's packing, under cover
- When opening the coils take care not to damage the pipe (do not use sharp objects), use SAFECUT from accessories
- The unrolling of the coils must take place in the opposite direction to rolling up, so starting with the pipe end on the outside of the reel
- Do not use pipe with folds, kinks or that has been damaged
- Pipes must always be laid without twists
- Pipes must be protected against any distortion, soiling and/or damage.
- Pipes must be installed using Henco recommended tools
- Pipes must be cut square, and the ends of the pipe must always be calibrated and deburred according to the specified instructions
- Pipe bends can be formed by hand, but to achieve bends with a minimum radius an internal or external bending spring must be used
- The bare pipe may not come into contact with sharp objects during and after laying. For example, piping running through ceiling holes may not be bent around sharp edges as there is a danger of kinking
- If further bending of the pipes is required after installation of fittings, it is recommended that the pipe be supported by hand at the connection
- After laying, the pipes must be protected from on-site damage. A protective sleeve or insulation is recommended
- When surface mounting, pipe brackets, expansion bends and expansion loops must be used as specified.

To qualify for the Henco system guarantee, Henco multilayer pipe and fittings must be installed and assembled exactly in accordance with Pegler Yorkshire published instructions.

### Bending Henco pipe

The Henco pipe must be bent without heat application. For pipes having a diameter larger than Ø26 elbow fittings should be used. The pipes can be bent manually as well as with an internal or external spiral spring.

Minimum bend radii for pipes up to and including 26mm are shown in the table below.

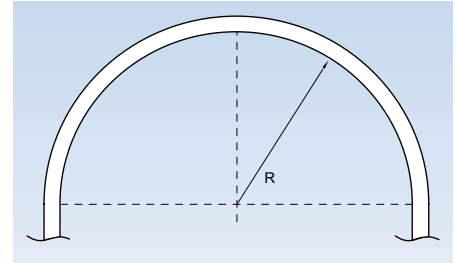

PIPE	MINIMUM BEND RADIUS	
	MANUAL/EXTERNAL SPIRAL SPRING (mm)	INTERNAL SPIRAL SPRING (mm)
	Standard	Standard
14 x 2	R 70 (5xOD)	R 42 (3xOD)
16 x 2	R 80 (5xOD)	R 48 (3xOD)
20 x 2	R 100 (5xOD)	R 60 (3xOD)
26 x 3	R 130 (5xOD)	R 78 (3xOD)



Bending with external spiral spring



Bending with internal spiral spring



Bending manually

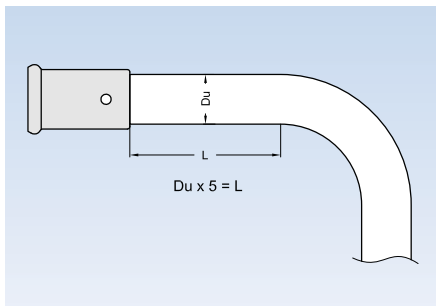

The bend should start at least 5 x the outer diameter of the pipe.

**Never use damaged or cracked pipes!**



## Making a press-fit connection

### Step by step

Correct pipe end preparation is essential for a trouble-free installation. Pegler Yorkshire only recommends the use of Kalispeed pipe calibration tools to prepare Henco multilayer pipe. Failure to use recommended tools will invalidate the Henco System guarantee.

1. When opening the coil never cut into the packing paper with a sharp object.



2. Always cut the pipe 90° square. For all diameters, and in particular Ø26 and greater, use of the RS32 or RS63 pipe cutter is recommended.



RSRESS guillotine cutter



RS32 wheel cutter

3. Calibrate the pipe with the Kalispeed tool. Slide the calibrator right into the pipe and then rotate it so that the cutter forms a continuous bevel to both the inner and outer edge of the pipe. Remove all swarf.

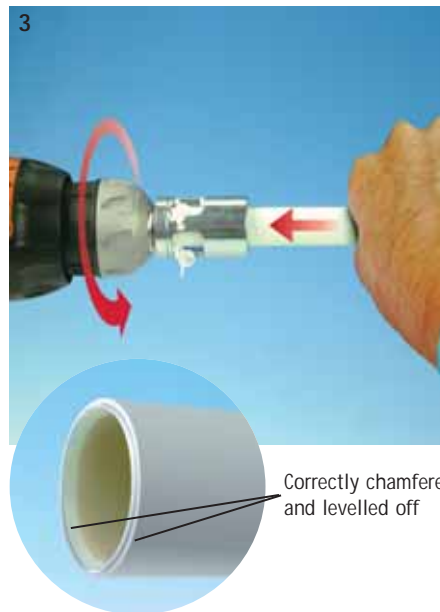

4. Slide the calibrated pipe all the way into the press fitting so the pipe is visible through the windows.



5. Open the compression jaw and ensure that the shoulder of the fitting is located in the groove of the jaws. To ensure correct compression, operate the press tool until the jaws release automatically keeping your hands safely away from the joint during the pressing process.



6. After the procedure is complete, open the compression jaws and check whether the pipe is still correctly mounted. If successful mark the fitting as complete.



*To qualify for the Henco System guarantee, Henco multilayer pipe and fittings must be installed and assembled exactly in accordance with Pegler Yorkshire published instructions.*

### Pressing without stresses

It is vital not to apply stresses to the pipework whilst installing during press-jointing. Pipes with fittings already pressed must also be kept free of stresses during further assembly.

Once a fitting has been fitted to the pipe at one end using a press connection, the pipe may no longer cause any stresses on the fitting. If further bending is required, the pipe must be fully supported by hand and not the fitting.

If using a combination of fitting types, any threaded connections must be installed first followed by press joints.



### Required assembly space for the pressing jaw

REQUIRED ASSEMBLY SPACE FOR HENCO PRESSING JAWS (TYPE BE AND BE-MINI*)					
	X1	Z1	X2	Y2	Z2
14 x 2	30	65	40	40	90
16 x 2	30	65	40	40	90
18 x 2	30	65	40	40	90
20 x 2	30	65	40	40	90
26 x 3	35	70	50	50	100
32 x 3	35	75	50	50	110
40 x 3.5	50	110	70	70	135
50 x 4.0	55	115	75	75	135
63 x 4.5	90	120	95	95	140

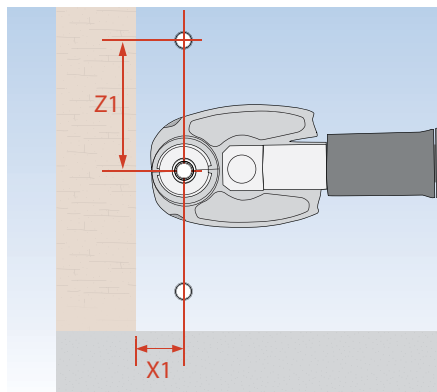
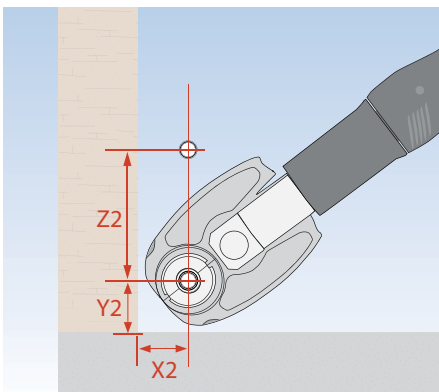

### Health and safety

1. We recommend that eye protection is worn when operating all pressing tools.
2. Do not activate a pressing tool without a fitting in the jaws.

Note: when using power tools, great care must be taken at all times. Always refer to the manufacturers' instructions for all machines and tools you use.



## Compatibility of press jaws

### PVDF fittings

<i>Pipe size</i>	<i>Jaw profile</i>	<i>Other approved</i>
14-26mm	BE	TH Profile
32-63mm	BE	None

### Brass fittings

<i>Pipe size</i>	<i>Jaw profile</i>
14-26mm	TH
32mm	THL
40-63mm	TH

## Hire companies

Tools can be obtained from recommended hire companies:

Broughton Plant Hire

10 Trade City, Ashton Road, Romford, Essex RM3 8UJ

Tel: 01708 383 350 Fax: 01708 383 359

J.M.S.

32 Coldharbour Lane, Harpenden, Hertfordshire AL5 4UN

Tel: 01582 467 000 Fax: 01582 467 999

M.E.P Hire Station.

Unit K, Ashley Drive, Bothwell Industrial Estate, Glasgow G71 8BC

Tel: 01698 811 114 Fax: 01698 817 098

or contact us or your local reputable hire company.

## General instructions for installing the pipe

Before carrying out High Pressure Testing, Pegler Yorkshire recommends that the system is pressurised to 0.5bar and the fittings are individually inspected and the appropriate action is taken where a leak is detected.

### Pressure test for sanitary installations (DIN 1988)

- Use pressure gauges which can measure a pressure difference of 0.1bar
- The pressure gauge must be fitted at the lowest point of the installation
- The installation must not be concealed
- The pipes are filled with water, all air excluded.

### The introductory test

- The pressure test takes place at a pressure of 15bar
- The installation must be put under this pressure twice for 30 minutes, with an interval of 10 minutes
- Then another 30 minute test in which the pressure must not drop by more than 0.6bar and the installation must remain watertight.

### The main test

- The main test must take place immediately after the introductory test
- This test must last for 2 hours
- The pressure measured in the introductory test must not have dropped by more than 0.2bar after these 2 hours
- The installation must remain 100% watertight.

### Pressure test for radiator installation (DIN 18380)

- The installer must check the sealing of the water pipes before these are concealed with cement, plaster or other materials

- Use pressure gauges which can measure a pressure difference of 0.1bar
- The pressure gauge must be fitted at the lowest point of the installation
- The heating installation must be put under water pressure and de-aerated (if necessary protected against frost)
- The heating pipe must undergo a pressure test at a pressure 1.3 times greater than the total pressure of the installation (static pressure), with at least 1bar over-pressure at each point of the installation
- The pressure test must take place over 24 hours
- The pressure must not drop by more than 0.2bar
- The installation must remain watertight
- Once the water has cooled down check whether all the pipes and fittings have remained watertight.

## UV-resistance

The Henco multilayer pipe must be protected against direct sunlight or UV radiation. Once removed from the packaging it must be covered during storage or transport. If when under construction the pipes are fitted with a protective sleeve or insulation, they are then perfectly protected against UV radiation.

## Legionnaire's disease

Legionella bacteria occur in all fresh water and also mains water, but they can only grow and become a risk under a number of specific conditions which particularly concern the design and maintenance of the installation, and not the type of pipe used in the installation. The temperature of the water plays an important part. The bacteria are inactive and therefore not dangerous below 25°C. A water temperature of 60°C is too hot. The bacterium does not like running water. The danger occurs in water

with a temperature between 25°C and 50°C that has atomised. If the conditions are favourable for the bacterium, old pipes that are damaged or otherwise affected by corrosion can assist the growth of the legionella bacterium.

The Henco pipe is corrosion-resistant thanks to the smooth wall of the cross-linked inner pipe. Only preventive measures can be taken such as:

- Set the temperature of the boiler so that the supply pipe stays at a temperature of least 60°C. Set the return to 50°C and have the mixing take place as near as possible to the sanitary branch point (e.g. shower)
- Regularly rinse all pipes with sufficiently hot water, certainly after a long absence
- Empty unused piping
- The system should be designed to avoid sections of pipework with undue stagnation and dead-legs.

## Fire classification

The Henco multilayer pipe, consisting of two cross-linked polyethylene layers and a butt welded aluminium layer, belongs according to DIN 4102 part 1 to class B2 (normally inflammable construction elements).





# Pegler Yorkshire

*Our brands:*

**terrier**

HEATING SOLUTIONS

**YORKSHIRE**

SOLDER RING SOLUTIONS

**Tectite**

PUSH-FIT SOLUTIONS

**XPress**

PRESS-FIT SOLUTIONS

**ENDEX**

END FEED SOLUTIONS

**KUTERLITE**

COMPRESSION SOLUTIONS

**PRESTEX**

DOMESTIC VALVE SOLUTIONS

**PEGLER**

COMMERCIAL VALVE SOLUTIONS

**meibes**

RENEWABLE SOLUTIONS

**PERFORMA**

UTILITY TAP SOLUTIONS

francis  
pegler

LUXURY TAP SOLUTIONS

## *UK sales*

Free Phone: 0800 156 0010

Free Fax: 0808 156 1011

Email: [uk.sales@pegleryorkshire.co.uk](mailto:uk.sales@pegleryorkshire.co.uk)

## *Export*

Tel: +44 (0) 1302 855 656

Fax: +44 (0) 1302 730 513

Email: [export@pegleryorkshire.co.uk](mailto:export@pegleryorkshire.co.uk)

## *Technical Help*

Free Phone: 0800 156 0050

Free Fax: 0808 156 1012

Email: [tech.help@pegleryorkshire.co.uk](mailto:tech.help@pegleryorkshire.co.uk)

## *Brochure Hotline*

Free Phone: 0800 156 0020

Free Fax: 0808 156 1011

Email: [info@pegleryorkshire.co.uk](mailto:info@pegleryorkshire.co.uk)

[www.pegleryorkshire.co.uk](http://www.pegleryorkshire.co.uk)

## **Pegler Yorkshire Group Limited**

St. Catherine's Avenue, Doncaster,  
South Yorkshire, DN4 8DF, England.

Tel: 0844 243 4400 Fax: 0844 243 9870

Registered in England Company No. 00401507

Registered Office: Haigh Park Road, Stourton, Leeds,  
West Yorkshire, LS10 1RT, England.

All brand names and logo styles are registered trademarks.  
Maintaining a policy of continual product development,  
Pegler Yorkshire reserves the right to change specifications, design  
and materials of products listed in this publication without prior notice.

LIT.REF: 880132.02.11